

受 控

SPECIFICATION

CUSTOMER : QUARTZ-1

PRODUCT NAME : Piezoelectric Diaphragm

CUSTOMER MODEL NO. :

KEPO MODEL NO. : FT-50T-3.0AL150-G(G)-562

ORDER:



DRAWING : KCC562

Compliance With RoHS

Signature of Approval

--

Signature of KEPO

Approved by	Check by	Issued by	Date
			



宁波凯普电子有限公司

Ningbo Kepo Electronics Co.,Ltd.

宁波东钱湖镇东钱湖工业区宝源路 25 号

TEL:+86-574-88370330 FAX:+86-574-88370329

No.25 Baoyuan road Dongqian Lake, Industry Area, Dongqian town,
Ningbo City, China(Post Code:315121)

Sales@chinaacoustic.com www.chinaacoustic.com

Specificion for Piezoelectric Diaphragm	Drawing No.	Revision No.	Page
Model No. : FT-50T-3.0AL150-G(G)-562	KCC562	1.0	2/9

CONTENTS

1. Scope 范围
2. Model No. 产品型号
3. Test Conditions 测试条件
4. Maximum Rating 最大输入
5. Electrical Characteristics 产品特性
6. Measuring Method 检测方法
7. Environmental Characteristics 环境特性
8. Physical Characteristics 物理特性
9. Dimensions 尺寸
- 10.Packing 包装
- 11.Revision 履历

Specificion for Piezoelectric Diaphragm	Drawing No.	Revision No.	Page
Model No. : FT-50T-3.0AL150-G(G)-562	KCC562	1.0	3/9

1. Scope

This product specification is applied to the piezoelectric element used for sounder in alarm systems. Please contact us when using this product for any other applications than described in the above.

该规格书适用于报警提醒装置中的蜂鸣片产品，若有其他用途，请和我们联系。

2.Model No. : FT-50T-3.0AL150-562

3.Test Conditions

Product shall be measured under a condition (Temperature :+15 to +35°C,Humidity :45 to 85%R.H.,Atmosphere:86~106kPa)unless the standard condition (Temperature :+25 ± 3°C,Humidity :60 ± 10%R.H.,Atmosphere:86~106kPa) is regulated measure.

除了在标准条件下（温度：25±3° C，湿度：60±10%R.H，气压：86-106Kpa)可以进行常规测试，其他应在（温度：+15-35° C，湿度：45-85%R.H，气压：86-106Kpa)条件下测试。

4. Maximum Rating

	Item	Specification
4.1	Maximum Input Voltage 最大输入电压	30 Vp-p /Max.
4.2	Operating Temperature Range 工作温度范围	-20 ~ +60 °C
4.3	Storage Temperature Range 储藏温度范围	-20 ~ +70 °C

5. Electrical Characteristics

	Item	Specification
5.1	Resonant Frequency 谐振频率	3.0± 0.3 KHz
5.2	Resonant Impedance 谐振阻抗	500 Ω /Max
5.3	Electrostatic Capacity (at 100Hz) 静电电容	30000pF ± 30%

Specificion for Piezoelectric Diaphragm	Drawing No.	Revision No.	Page
Model No. : FT-50T-3.0AL150-G(G)-562	KCC562	1.0	4/9

6. Measuring Method

6.1 Resonant Frequency / Resonant Impedance

谐振频率/ 谐振阻抗

Piezoelectric diaphragm shall be clamped at a node point as shown in following figure to be free from any mechanical stress, and measured its resonant frequency and resonant impedance by using vector impedance analyzer or equivalent.

压电蜂鸣片被放置在夹具中，（如下图所示）以便在夹具中自由振动，并且用专业的阻抗仪器进行测量。

When the input frequency is swept within 3 to 12 kHz, the resonant frequency is defined the frequency where the impedance shows minimum value, and this impedance shall be the resonant impedance.

当输入扫描频率3-12KHz时，显示最小谐振阻抗的点就是谐振频率，这点显示的值就是谐振阻抗。

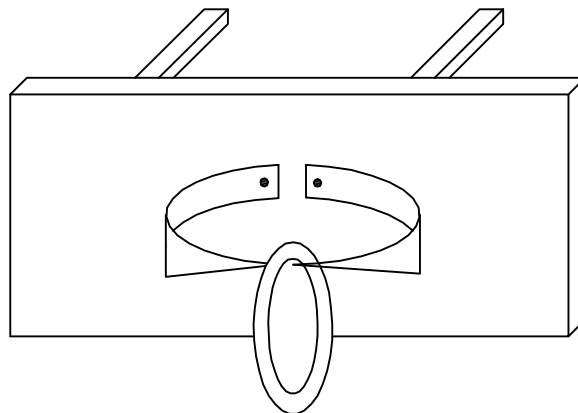

6.2 Electrostatic Capacitance

A electrostatic capacity capacitance shall be measured at 100Hz by using L.C.R.meter, ex. HP4192A(H.P.), or equivalent.

用L.C.R.电桥100Hz频率下进行测试。

6.3 Insulation resistance

An insulation resistance shall be measured by using an insulation resistance meter.

用绝缘阻抗测试仪来进行测试。

Specificion for Piezoelectric Diaphragm	Drawing No.	Revision No.	Page
Model No. : FT-50T-3.0AL150-G(G)-562	KCC562	1.0	5/9

7. Environmental Characteristics

	Item	Test Condition	Specification
7.1	Dry Heat Test (Storage) 最高存储温度 试验	After being placed in a chamber with $+70 \pm 2^{\circ}\text{C}$ for 240 hours and then being placed in natural condition for 4 hours, diaphragm shall be measured. 在 $+70 \pm 2^{\circ}\text{C}$ 的条件下放置240小时, 再在常温下放置4小时, 测试其数据	The measured value shall meet Table 1. 测试数据符合表1.
7.2	Cold Test (Storage) 最低存储温度 试验	After being placed in a chamber with $-20 \pm 2^{\circ}\text{C}$ for 240 hours and then being placed in natural condition for 4 hours, diaphragm shall be measured. 在 $-20 \pm 2^{\circ}\text{C}$ 的条件下放置240小时, 再在常温下放置4小时, 测试其数据	
7.3	Humidity 湿度试验	After being placed in a chamber with 90 to 95 %R.H. at $+40 \pm 2^{\circ}\text{C}$ for 240 hours and then being placed in natural condition for 4 hours, diaphragm shall be measured. 在湿度为90~95%R.H, 温度为 $+40 \pm 2^{\circ}\text{C}$ 的条件下放置240小时, 再在常温下放置4小时, 测试其数据	
7.4	Temperature Cycle 温度循环试验	After being placed in a chamber at $-20 \pm 2^{\circ}\text{C}$ for 30 minutes, diaphragm shall be placed at room temperature($+20^{\circ}\text{C}$).After 15 minutes at this temperature ,diaphragm shall be placed in a chamber at $+70 \pm 2^{\circ}\text{C}$. After 30 minutes at this temperature, diaphragm shall be returned to room temperature ($+20^{\circ}\text{C}$) for 15 minutes. After 5 above cycles, sounder shall be measured after being placed in natural condition for 4 hours. 蜂鸣片被放置在 $-20 \pm 2^{\circ}\text{C}$ 的条件30分钟, 再在 20°C 的常温下放置15分钟, 再放置 $+70 \pm 2^{\circ}\text{C}$ 的条件30分钟, 再在 20°C 的常温下放置15分钟为一个周期, 经过5个周期后测试其数据.	

Specificion for Piezoelectric Diaphragm	Drawing No.	Revision No.	Page
Model No. : FT-50T-3.0AL150-G(G)-562	KCC562	1.0	6/9

8. Physical Characteristics

	Item	Test Condition	Specification
8.1	Shock 碰撞试验	Diaphragm shall be measured after being applied shock(980m/s ²) for each three mutually perpendicular directions to each of 3 times by half sine wave. 蜂鸣片在加速度980m/s ² , 三个轴向, 每个轴向半正弦波碰撞三次.	The measured value shall meet Table 1. 测试数据符合表1.
8.2	Vibration Resistant 振动试验	Diaphragm shall be measured after being applied vibration of amplitude of 1.5mm with 10 to55Hz band of vibration frequency to each of 3 perpendicular directions for 2 hours. 蜂鸣片在振幅为1.5mm, 振动频率为: 10-55Hz, 三个轴向每振动2小时.	

Table 1.

	Item	Specification after test
1	Resonant Frequency 谐振频率	Initial Value ± 15% 初始值± 15%
2	Resonant Impedance 谐振阻抗	800 Ω /max
3	Electrostatic Capacity 静电容量	Initial Value ± 30% 初始值± 30%

Specificion for Piezoelectric Diaphragm	Drawing No.	Revision No.	Page
Model No. : FT-50T-3.0AL150-G(G)-562	KCC562	1.0	7/9

9. Dimensions

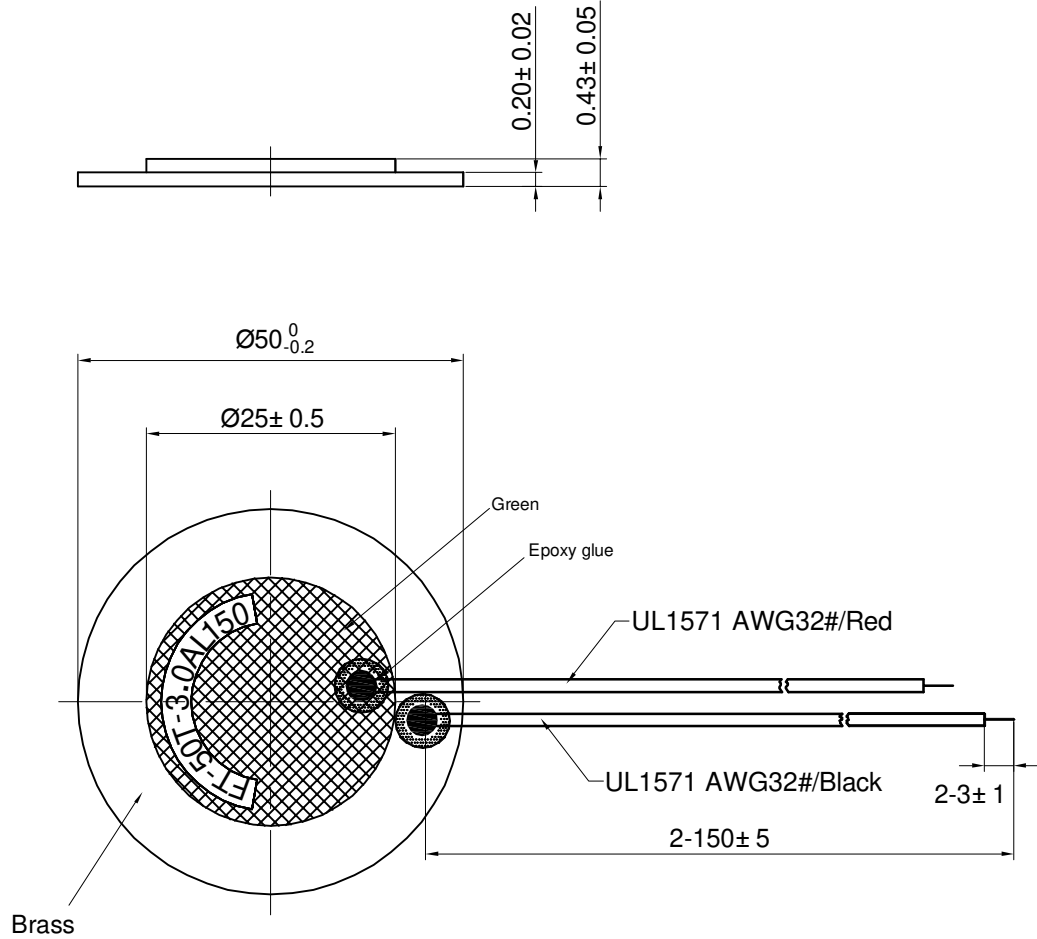

FIRST ANGLE PROJECTION



UNIT : mm

Specifiction for Piezoelectric Diaphragm	Drawing No.	Revision No.	Page
Model No. : FT-50T-3.0AL150-G(G)-562	KCC562	1.0	8/9

10. Packing

Each minimum package unit of products shall be in a carton box and it shall be clearly marked with Part Number, quantity and outgoing inspection number. There shall be no mechanical damage on products during transportation and/or in storage.

把小包装放入大包装内，必须清楚的标记产品型号、数量、生产批号等，外箱不能有机械损伤。

Specificion for Piezoelectric Diaphragm	Drawing No.	Revision No.	Page
Model No. : FT-50T-3.0AL150-G(G)-562	KCC562	1.0	9/9

11. Revision

Rev. No.	DATE	PAGE	DESCRIPTION	SIGN
1.0	2010.12.06	/	primary	