



T-75-37-05

UM8250B

Asynchronous Communication Element (ACE)



Feature

- Adds or deletes standard asynchronous communication bits (start, stop, and parity) to or from a serial data stream
- Full double buffering eliminates the need for precise synchronization
- Independently controlled transmit, receive, line status, and data set interrupts
- Programmable baud rate generator allows division of any input clock by 1 to $(2^{16}-1)$ and generates the internal 16x clock
- Independent receiver clock input
- Modem control functions (CTS, RTS, DSR, DTR, RI, and carrier detect)
- Single +5 volt power supply
- TRI-STATE TTL drive capabilities for bidirectional

- data bus and control bus.
- Fully programmable serial-interface characteristics:
 - 5-, 6-, 7-, or 8-bit characters
 - Even, odd, or no-parity bit generation and detection
 - 1, 1½, or 2-stop bit generation
 - Baud rate generation (DC to 56K baud)
- False start bit detection
- Complete status reporting capabilities
- Easily interfaces to most popular microprocessors
- Line break generation and detection
- Internal diagnostic capabilities
 - Loopback controls for communications link fault isolation
 - Break, parity, overrun, framing error simulation
- Fully prioritized interrupt system controls

General Description

The UM8250B is a programmable Asynchronous Communication Element (ACE) chip fabricated using Si-Gate NMOS process. This product performs serial-to-parallel conversion on data characters received from a peripheral device or a modem, and parallel-to-serial conversion on data characters received from the CPU. The CPU can read the complete

status of the ACE at any time during operation. It also includes a programmable baud rate generator that is capable of dividing the timing reference clock input by a divisor of 1 to $(2^{16}-1)$, and producing a 16X clock for driving the internal transmitter logic.

I/O And Peripherals

Pin Configurations

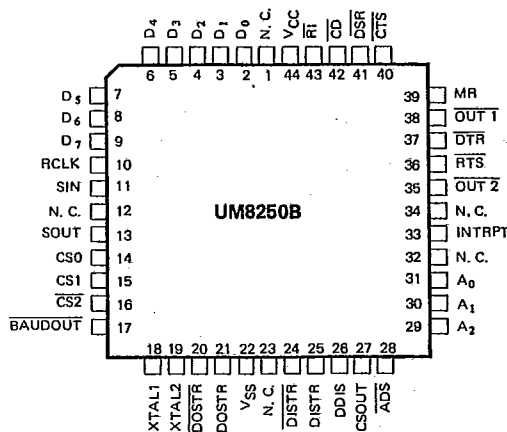
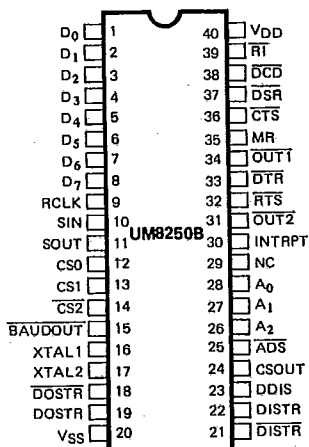



T-75-37-05

UM8250B

Block Diagram

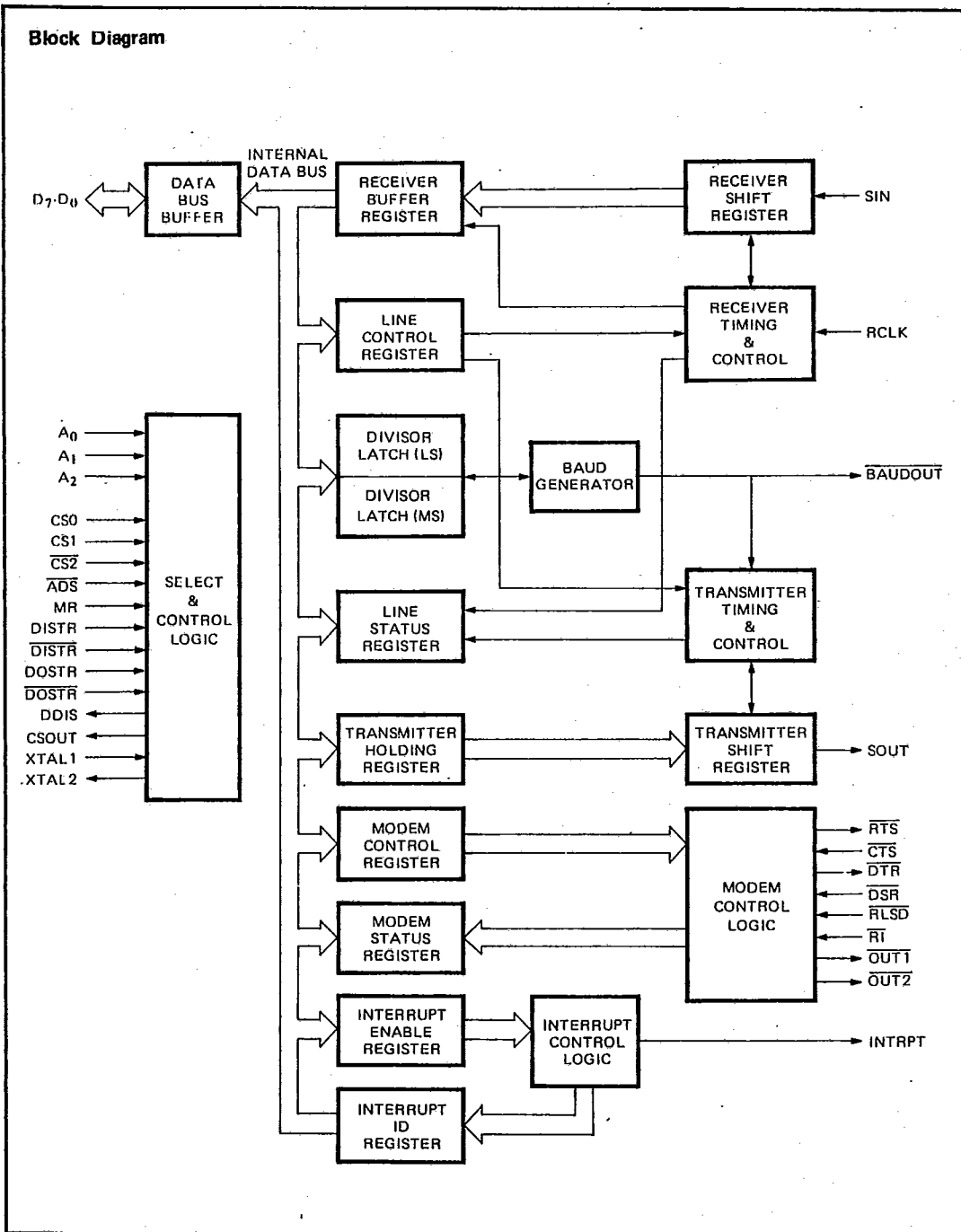



T-75-37-05

UM8250B

Absolute Maximum Ratings*

Temperature Under Bias 0°C to +70°C
 Storage Temperature -65°C to +150°C
 All Input or Output Voltages with Respect to V_{SS} -0.5V to +7.0V
 Power Dissipation 700mW

***Comments**

Stresses above those listed under "Absolute Maximum Ratings" may cause permanent damage to the device. These are stress ratings only. Functional operation of this device at these or any other conditions above those indicated in the operational sections of this specification is not implied and exposure to absolute maximum rating conditions for extended periods may affect device reliability.

DC Electrical Characteristics

T_A = 0°C to +70°C, V_{CC} = +5V ± 5%, V_{SS} = 0V, unless otherwise specified.

Symbol	Parameter	Conditions	Min.	Max.	Units
V _{ILX}	Clock Input Low Voltage		-0.5	0.8	V
V _{IHX}	Clock Input High Voltage		2.0	V _{CC}	V
V _{IL}	Input Low Voltage		-0.5	0.8	V
V _{IH}	Input High Voltage		2.0	V _{CC}	V
V _{OL}	Output Low Voltage	I _{OL} = 1.6 mA on all*		0.4	V
V _{OH}	Output High Voltage	I _{OL} = -1.0 mA*	2.4		V
I _{CC (AV)}	Avg Power Supply Current (V _{CC})	V _{CC} = 5.25V, T _A = 25°C No Loads on output SIN, DSR, RLS, D, CTS, RI = 2.0V All other inputs = 0.8V		90	mA
I _{IL}	Input Leakage	V _{CC} = 5.25V, V _{SS} = 0V All other pins floating. V _{IN} = 0V, 5.25V		± 10	μA
I _{CL}	Clock Leakage			± 10	μA
I _{OZ}	TRI-STATE Leakage	V _{CC} = 5.25V, V _{SS} = 0V V _{OUT} = 0V, 5.25V 1) Chip deselected 2) WRITE Mode, chip selected		± 20	μA
V _{ILMR}	MR Schmitt V _{IL}			0.8	V
V _{IHMR}	MR Schmitt V _{IH}		2.0		V

* Does not apply to XTAL2

Capacitance

T_A = 25°C, V_{CC} = V_{SS} = 0V

Symbol	Parameter	Conditions	Min.	Typ.	Max.	Units
C _{XTAL2}	Clock Input Capacitance			15	20	pF
C _{XTAL1}	Clock Output Capacitance	f _C = 1 MHz		20	30	pF
C _{IN}	Input Capacitance	Unmeasured pins returned to V _{SS}		6	10	pF
C _{OUT}	Output Capacitance			10	20	pF

I/O And Peripherals



T-75-37-05

UM8250B

AC Characteristics

T_A = 0°C to +70°C, V_{CC} = +5V ± 5%

Symbol	Parameter	Conditions	Min.	Max.	Unit
t _{AW}	Address Strobe Width		90	—	ns
t _{AS}	Address Setup Time		90		ns
t _{AH}	Address Hold Time		0		ns
t _{CS}	Chip Select Setup Time		90		ns
t _{CH}	Chip Select Hold Time		0		ns
t _{DIW}	DISTR/DISTR Strobe Width		175		ns
t _{RC}	Read Cycle Delay		500		ns
RC	Read Cycle = t _{AR} * + t _{DIW} + t _{RC}		755		ns
t _{DD}	DISTR/DISTR to Driver Disable Delay	@ 100 pF loading***		125	ns
t _{DDD}	Delay from DISTR/DISTR to Data	@ 100 pF loading		175	ns
t _{HZ}	DISTR/DISTR to Floating Data Delay	@ 100 pF loading***		150	ns
t _{DOW}	DOSTR/DOSTR Strobe Width		175		ns
t _{WC}	Write Cycle Delay		500		ns
WC	Write Cycle = t _{AW} + t _{DOW} + t _{WC}		755		ns
t _{DS}	Data Setup Time		90		ns
t _{DH}	Data Hold Time		60		ns
t _{CSC} *	Chip Select Output Delay from Select	@ 100 pF loading		125	ns
t _{RA} *	Address Hold Time from DISTR/DISTR		50		ns
t _{RCS} *	Chip Select Hold Time from DISTR/DISTR		20		ns
t _{AR} *	DISTR/DISTR Delay from Address		80		ns
t _{CSR} *	DISTR/DISTR Delay from Chip Select		80		ns
t _{WA} *	Address Hold Time from DOSTR/DOSTR		50		ns
t _{WCS} *	Chip Select Hold Time from DOSTR/DOSTR		20		ns
t _{AW} *	DOSTR/DOSTR Delay from Address		80		ns
t _{CSW} *	DOSTR/DOSTR Delay from Select		80		ns
t _{MRW}	Master Reset Pulse Width		10		μs
t _{XH}	Duration of Clock High Pulse	External Clock (3.1 MHz Max.)	140		ns
t _{XL}	Duration of Clock Low Pulse	External Clock (3.1 MHz Max.)	140		ns
Baud Generator					
N	Baud Divisor		1	2 ¹⁶ -1	
t _{BLD}	Baud Output Negative Edge Delay	100 pF Load		250	ns
t _{BHD}	Baud Output Positive Edge Delay	100 pF Load		250	ns
t _{LW}	Baud Output Down Time	100 pF Load	425		ns
t _{HW}	Baud Output Up Time	100 pF Load	330		ns
Receiver					
t _{SCD}	Delay from RCLK to Sample Time			2	μs
t _{SINT}	Delay from Stop to Set Interrupt			1	RCLK** Cycles
t _{RINT}	Delay from DISTR/DISTR (RD RBR/RDL SR) to Reset Interrupt	100 pF Load		700	ns



AC Characteristics (Continued)

Symbol	Parameter	Conditions	Min.	Max.	Units
TRANSMITTER					
t_{HR}	Delay from $\overline{DOSTR}/DOSTR$ (WR THR) to Reset Interrupt	100 pF Load		700	ns
t_{IRS}	Delay from initial INTR Reset to Transmit Start			16	RCLK Cycles
t_{SI}	Delay from Initial Write to Interrupt			24	RCLK Cycles
t_{SS}	Delay from stop to Next start	100 pF Load		1	μ S
t_{STI}	Delay from Stop to Interrupt (THRE)			8	RCLK Cycles
t_{IR}	Delay from $\overline{DISTR}/DISTR$ (RD IIR) to Reset Interrupt (THRE)	100 pF Load		700	ns
MODEM CONTROL					
t_{MDO}	Delay from $\overline{DOSTR}/DOSTR$ (WR MCR) to Output	100 pF Load		700	ns
t_{SIM}	Delay to Set Interrupt from MODEM Input	100 pF Load		1000	ns
t_{RIM}	Delay to Reset Interrupt from $\overline{DISTR}/DISTR$ (RD MSR)	100 pF Load		700	ns

* Applicable only when \overline{ADS} is tied low.

** RCLK is equal to t_{XH} and t_{XL} .

*** Charge and discharge time is determined by V_{OL} , V_{OH} and the external loading.

Note: Timings assume one level of multiplexers around the ACE to facilitate testing. Some variation in timings may result from non-typical placement/routing.

Timing Waveforms

EXTERNAL CLOCK INPUT (3.1 MHz MAX.)

AC TEST POINTS

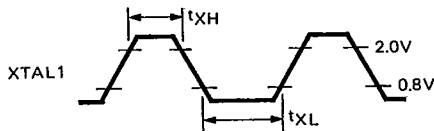

I/O And Peripherals

BAUDOUT TIMING

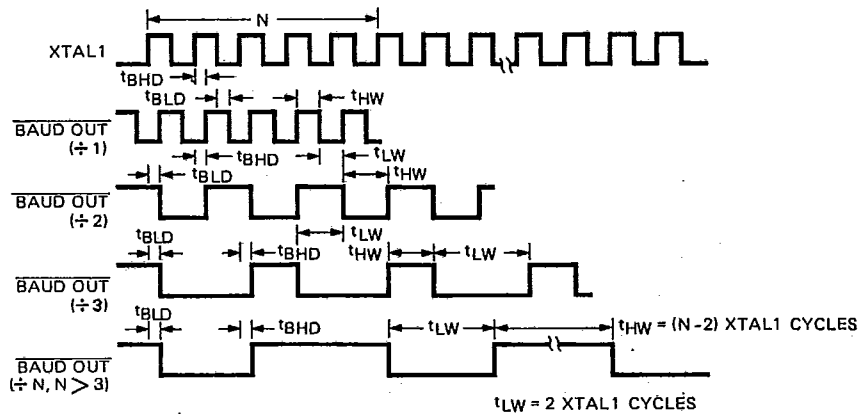



T-75-37-05

UM8250B

Timing Waveforms (Continued)

WRITE CYCLE

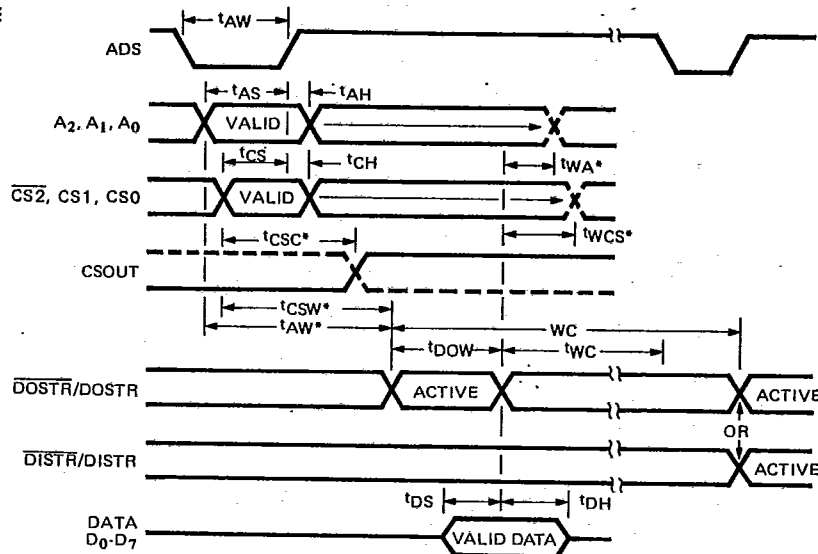

* Applicable Only When \overline{ADS} is Tied Low.

READ CYCLE

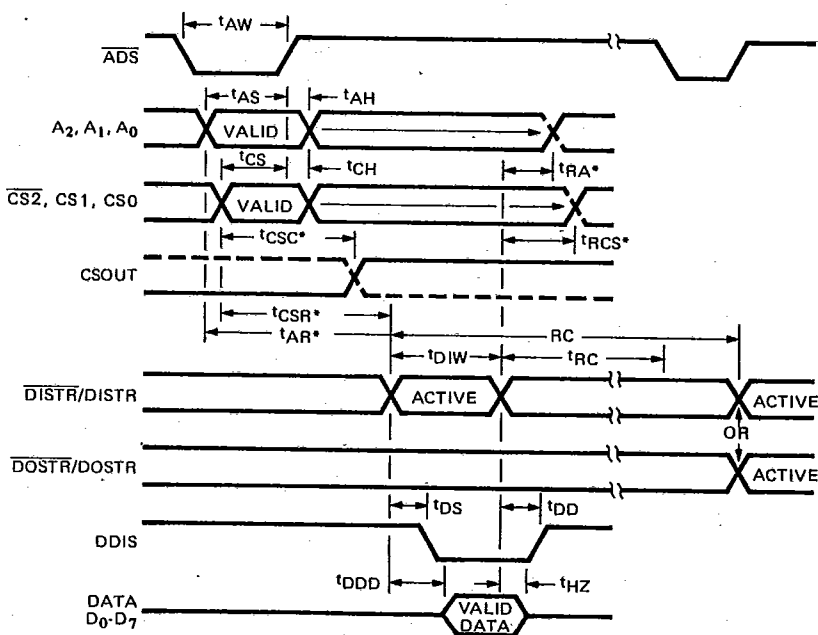

* Applicable Only When \overline{ADS} is Tied Low.



T-75-37-05

UM8250B

Timing Waveforms (Continued)

RECEIVER TIMING

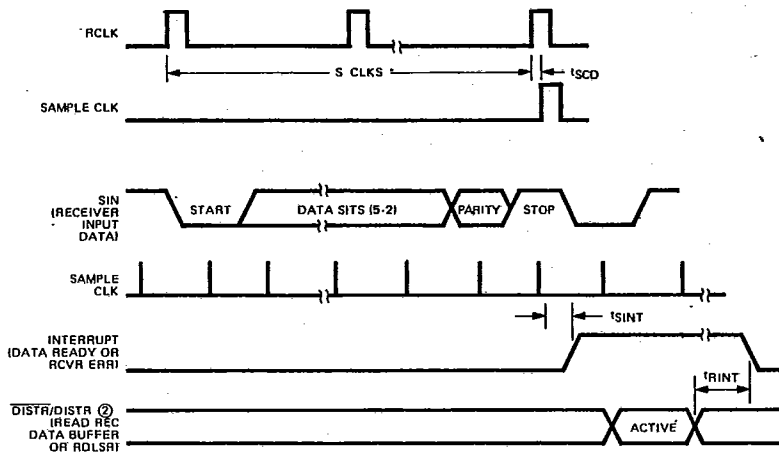

TRANSMITTER TIMING

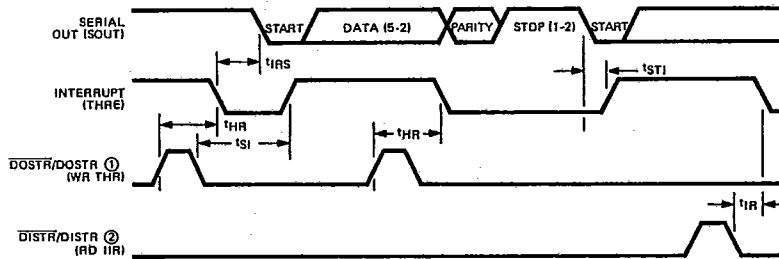

MODEM CONTROL TIMING

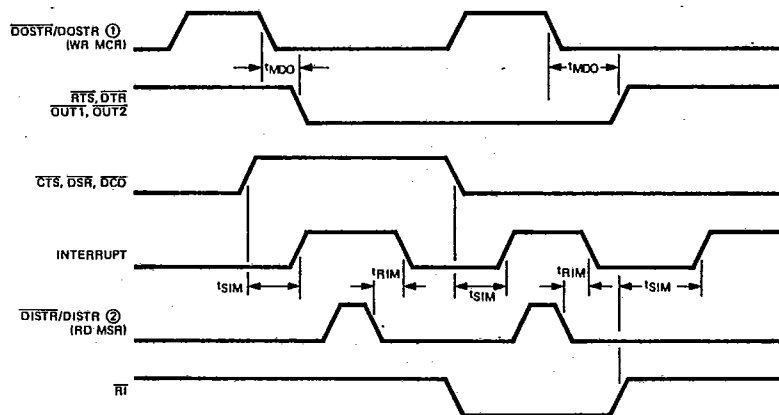

1: See Write Cycle Timing
2: See Read Cycle Timing

I/O And Peripherals



T-75-37-05

UM8250B

Typical Application

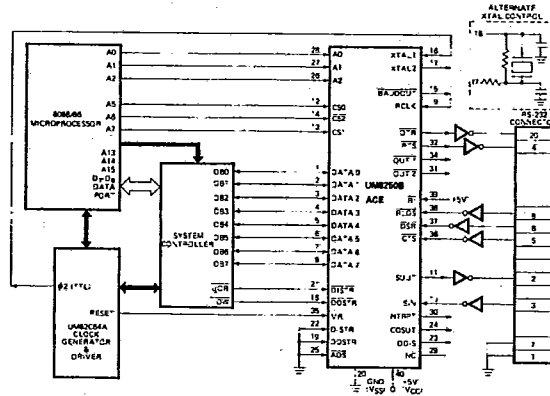

Pin Description

Input Signal

Chip Select (CS0, CS1, $\overline{CS2}$), Pins 12–14: When CS0 and CS1 are high and $\overline{CS2}$ is low, the chip is selected. Chip selection is complete when the decoded chip select signal is latched with an active (low) Address Strobe (\overline{ADS}) input.

Data Input Strobe (DISTR, \overline{DISTR}), Pins 21 and 22: When DISTR is high or when \overline{DISTR} is low, the chip is selected; it allows the CPU to read status information or data from a selected register of the UM8250B.

Data Output Strobe (DOSTR, \overline{DOSTR}), Pins 18 and 19: The chip is selected when DOSTR is high or \overline{DOSTR} is low and allows the CPU to write data or control words into a selected register of the UM8250B.

* Note that only one of these two inputs, DISTR and \overline{DISTR} (DOSTR and \overline{DOSTR}) is needed to activate the CPU read (Write). Tie either DISTR (DOSTR) low or \overline{DISTR} (\overline{DOSTR}) high if not needed.

Address Strobe (\overline{ADS}), Pin 25: When low, provides latching for the Register Select (A_0, A_1, A_2) and Chip Select (CS0, CS1, $\overline{CS2}$) signals. An active \overline{ADS} input is required when the Register Select (A_0, A_1, A_2) signals are not stable for the duration of a read or write operation. If not required, tie the \overline{ADS} input permanently low.

Register Select (A_0, A_1, A_2), Pins 26–28: These three inputs are used during a read or write operation to select a UM8250B register to read from or write into as indicated in Table 1. Note that the state of the Divisor Latch Access Bit (DLAB), which is the most significant bit of the Line Control Register, affects the selection of certain UM8250B registers. The DLAB must be set high by the system software to access the Baud Generator Divisor Latches.

Receiver Clock (RCLK), Pin 9: This input is the 16X baud rate clock for the receiver section of the chip.

Serial Input (SIN), Pin 10: Serial data input from the communications link (peripheral device, MODEM, or data set).

Clear to Send (\overline{CTS}), Pin 36: The \overline{CTS} signal is a MODEM control function input whose conditions can be tested by the CPU by reading bit 4 (CTS) of the MODEM Status Register. Bit 0 (DCTS) of the MODEM Status Register indicates whether the \overline{CTS} input has changed state since the previous reading of the MODEM Status Register. CTS has no effect on the Transmitter. Whenever the CTS bit of the MODEM Status Register changes state, an interrupt is generated if the MODEM Status Interrupt is enabled.

Data Set Ready (\overline{DSR}), Pin 37: When low, this indicates that the MODEM or data set is ready to establish the communications link and transfer data with the ACE. The DSR signal is a MODEM-control function input whose condition can be tested by the CPU by reading bit 5 (DSR) of the MODEM Status Register. Bit 1 (DDSR) of the MODEM Status Register indicates whether the \overline{DSR} input has changed state since the previous reading of the MODEM Status Register. Whenever the DSR bit of the MODEM Status Register changes state, an interrupt is generated if the MODEM Status Interrupt is enabled.

Data Carrier Detect (\overline{DCD}) Pin 38: When low, indicates that the data carrier has been detected by MODEM or data set.

The \overline{DCD} Signal is a MODEM Control function input and can be tested by reading bit 7 (DCD) of the MSR. Bit 3 (DDCD) of MSR indicates whether the \overline{DCD} input has changed state since the previous reading of MSR. Whenever the DCD bit of MSR changes state, an interrupt is generated if the MODEM Status Interrupt is enabled.



T-75-37-05

UM8250B

Table 1. Register Address

DLAB	A ₂	A ₁	A ₀	Register
0	0	0	0	Receiver Buffer (read), Transmitter Holding Register (write).
0	0	0	1	Interrupt Enable.
X	0	1	0	Interrupt Identification (read only).
X	0	1	1	Line Control.
X	1	0	0	MODEM Control.
X	1	0	1	Line Status.
X	1	1	0	MODEM Status.
X	1	1	1	None.
1	0	0	0	Divisor Latch (least significant byte).
1	0	0	1	Divisor Latch (most significant byte).

Ring Indicator (\overline{RI}), Pin 39: When low, indicates that a telephone ringing signal has been received by the MODEM or data set. The \overline{RI} signal is a MODEM-control function input whose condition can be tested by the CPU by reading bit 6 (RI) of the MODEM Status Register. Bit 2 (TERI) of the MODEM Status Register indicates whether the RI input has changed from a low to a high state since the previous reading of the MODEM Status Register. Whenever the \overline{RI} bit of the MODEM Status Register changes from a high to a low state, an interrupt is generated if the MODEM

Status Register is enabled.

Master Reset (MR), Pin 35: This input is buffered with a TTL-compatible Schmitt Trigger with 0.5V typical hysteresis. When high, it clears all the registers (except the Receiver Buffer, Transmitter Holding, and Divisor Latches) and the control logic of the UM8250B. Also, the state of various output signals (\overline{SOUT} , \overline{INTRPT} , $\overline{OUT 1}$, $\overline{OUT 2}$, \overline{RTS} , \overline{DTR}) are affected by an active MR input. (Refer to Table 2).

Table 2. Reset Function

Register/Signal	Reset Control	Reset State
Interrupt Enable Register	Master Reset	All bits Low (0-3 forced and 4-7 permanent).
Interrupt Identification Register	Master Reset	Bit 0 is High, Bits 1 and 2 Low, Bits 3-7 are Permanently Low.
Line Control Register	Master Reset	All Bits Low.
MODEM Control Register	Master Reset	All Bits Low.
Line Status Register	Master Reset	All Bits Low, Except Bits 5 and 6 which are High.
MODEM Status Register	Master Reset	Bits 0-3 Low, Bits 4-7 - Input Signal.
\overline{SOUT}	Master Reset	High
\overline{INTRPT} (RCVR Errs)	Read LSR/MR	Low
\overline{INTRPT} (RCVR Data Ready)	Read RBR/MR	Low
\overline{INTRPT} (THRE)	Read IIR/Write THR/MR	Low
\overline{INTRPT} (Modem Status Changes)	Read MSR/MR	Low
$\overline{OUT 2}$	Master Reset	High
\overline{RTS}	Master Reset	High
\overline{DTR}	Master Reset	High
$\overline{OUT 1}$	Master Reset	High

I/O And Peripherals



T-75-37-05

UM8250B**Output Signals**

Request to Send (RTS), Pin 32: When low, it informs the MODEM or data set that the UM8250B is ready to transmit data. The $\overline{\text{RTS}}$ output signal can be set to an active low by programming bit 1 (RTS) of the MODEM Control Register. The RTS signal is set high in a Master Reset operation.

Data Terminal Ready (DTR), Pin 33: When low, it informs the MODEM or data set that the UM8250B is ready to communicate. The DTR output signal can be set to an active low by programming bit 0 (DTR) of the MODEM Control Register to a high level. The DTR signal is set high in a Master Reset operation.

Output 1 ($\overline{\text{OUT 1}}$), Pin 34: User-designated output can be set to an active low by programming bit 2 ($\overline{\text{OUT 1}}$) of the MODEM Control Register to a high level. The $\overline{\text{OUT 1}}$ signal is set high in a Master Reset Operation.

Output 2 ($\overline{\text{OUT 2}}$), Pin 31: User-designated output can be set to an active low by programming bit 3 ($\overline{\text{OUT 2}}$) of the MODEM Control Register to a high level. The $\overline{\text{OUT 2}}$ signal is set high in a Master Reset Operation.

*Note that the $\overline{\text{RTS}}$, $\overline{\text{DTR}}$, $\overline{\text{OUT 1}}$ and $\overline{\text{OUT 2}}$ are forced to inactive state (high) during loop mode operation.

Chip Select Out (CSOUT), Pin 24: When high, it indicates that the chip has been selected by active, CS0, CS1, and CS2 inputs. No data transfer can be initiated until the CSOUT signal is a logic 1. When chip is not selected, CSOUT remains low.

Driver Disable (DDIS), Pin 23: This pin remains low whenever the CPU is reading data from UM8250B. A high-level output can be used to disable an external transceiver if the CPU is not reading.

Baud Out ($\overline{\text{BAUDOUT}}$), Pin 15: 16X clock signal for the transmitter section of the UM8250B. The clock rate is equal to the main reference oscillator frequency divided by the specified divisor in the Baud Generator Divisor Latches.

The $\overline{\text{BAUDOUT}}$ may also be used for the receiver section by tying this output to the RCLK input of the chip.

Interrupt (INTRPT), Pin 30: Goes high whenever any

of the following interrupt types has an active high condition and is enabled via the IER: Receiver Error Flag; Received Data Available; Transmitter Holding Register Empty and MODEM Status. The INTRPT signal is reset to low at the appropriate interrupt service or in a Master Reset operation.

Serial Output (SOUT), Pin 11: Composite serial data output to the communications link (peripheral, MODEM or data set). The SOUT signal is set to the Marking (logic 1) state in a Master Reset operation.

Input/Output Signals

Data (D_7-D_0) Bus, Pins 1-8: This bus comprises eight TRI-STATE input/output lines. The bus provides bidirectional communications between the UM8250B and the CPU. Data, control words, and status information are transferred via the D_7-D_0 Data Bus.

External Clock Input/Output (XTAL 1, XTAL 2), Pins 16 and 17: These two pins connect the main timing reference (crystal or clock signal) to the UM8250B.

Accessible Registers

There are 10 registers, as shown in Table 3, which may be accessed or controlled by the programmer via the CPU. These registers are used to control operations and to transmit and receive data.

Line Control Register

The system programmer specifies the format of the asynchronous data communications exchange via the Line Control Register. In addition to controlling the format, the programmer may retrieve the contents of the Line Control Register for inspection. This feature simplifies system programming and eliminates the need for separate storage in system memory of the line characteristics. The contents of the Line Control Register are indicated in Table 3 and are described below:

Bits 0 and 1: These two bits specify the number of bits in each transmitted or received serial character. The encoding of bits 0 and 1 is as follows:



T-75-37-05

UM8250B

Table 3 Summary of UM8250B Programmable Registers.

Bit No.	Register Address									
	0DLAB=0	0DLAB=0	1DLAB=0	2	3	4	5	6	0DLAB=1	1DLAB=1
	Receiver Buffer Register (Read Only)	Transmitter Holding Register (Write Only)	Interrupt Enable Register	Interrupt Ident. Register (Read Only)	Line Control Register	MODEM Control Register	Line Status Register	MODEM Status Register	Divisor Latch (LS)	Divisor Latch (MS)
	RBR	THR	IER	IIR	LCR	MCR	LSR	MSR	DLL	DLM
0	Data Bit 0*	Data Bit 0	Enable Received Data Available Interrupt (ERBFI)	"0" if Interrupt Pending	Word Length Select Bit 0 (WLS0)	Data Terminal Ready (DTR)	Data Ready (DR)	Delta Clear to Send (DCTS)	Bit 0	Bit 8
1	Data Bit 1	Data Bit 1	Transmitter Holding Register Empty Interrupt (ETBEI)	Interrupt ID Bit (0)	Word Length Select Bit 1 (WLS1)	Request to Send (RTS)	Overrun Error (OR)	Delta Data Set Ready (DDSR)	Bit 1	Bit 9
2	Data Bit 2	Data Bit 2	Enable Receiver Line Status Interrupt (ELSI)	Interrupt ID Bit (1)	Number of Stop Bits (STB)	Out 1	Parity Error (PE)	Trailing Edge Ring Indicator (TERI)	Bit 2	Bit 10
3	Data Bit 3	Data Bit 3	Enable MODEM Status Interrupt (EDSSI)	0	Parity Enable (PEN)	Out 2	Framing Error (FE)	Delta Data Carrier Detect (DDCD)	Bit 3	Bit 11
4	Data Bit 4	Data Bit 4	0	0	Even Parity Select (EPS)	Loop	Break Interrupt (BI)	Clear to Send (CTS)	Bit 4	Bit 12
5	Data Bit 5	Data Bit 5	0	0	Stick Parity	0	Transmitter Holding Register Empty (THRE)	Data Set Ready (DSR)	Bit 5	Bit 13
6	Data Bit 6	Data Bit 6	0	0	Set Break	0	Transmitter Shift Register Empty (TSRE)	Ring Indicator (RI)	Bit 6	Bit 14
7	Data Bit 7	Data Bit 7	0	0	Divisor Latch Access Bit (DLAB)	0	0	Data Carrier Detect (DCD)	Bit 7	Bit 15

*Bit 0 is the least significant bit. It is the first bit serially transmitted or received.

I/O And Peripherals



T-75-37-05

UM8250B

Bit 1	Bit 0	Word Length
0	0	5 Bits
0	1	6 Bits
1	0	7 Bits
1	1	8 Bits

Encoding of bit 0 and bit 1.

Bit 2: This bit specifies the number of Stop bits in each transmitted or received serial character. If bit 2 is a logic 0, 1 Stop bit is generated or checked in the transmit or receive data, respectively. If bit 2 is a logic 1 and a 5-bit word length is selected via bits 0 and 1, 1½ Stop bits are generated or checked. If bit 2 is a logic 1 and a 6-, 7-, or 8-bit word length is selected, 2 Stop bits are generated or checked.

Bit 3: This bit is the Parity Enable bit. When bit 3 is a logic 1, a Parity bit is generated (transmit data) or checked (receive data) between the last data word bit and Stop bit of the serial data. (The Parity bit is used to produce an even or odd number of 1s when the data word bits and the Parity bit are added.)

Bit 4: This bit is the Even Parity Select bit. When bit 3 is a logic 1 and bit 4 is a logic 0, an odd number of logic 1s is transmitted or checked in the data word bits and Parity bit. When bit 3 is a logic 1 and bit 4 is a logic 1, an even number of logic 1s are transmitted or checked.

Bit 5: This bit is the Stick Parity bit. When bit 3 is a logic 1 and bit 5 is a logic 1, the Parity bit is transmitted and then detected by the receiver as a logic 0 if bit 4 is a logic 1 or a logic 1, and if bit 4 is a logic 0.

Bit 6: This bit is the Break Control bit. When bit 6 is a logic 1, the serial output (SOUT) is forced to the Spacing (logic 0) state and remains there regardless of other transmitter activities. The set break is disabled by setting bit 6 to a logic 0. This feature enables the CPU to alert a terminal in a computer communications system.

Bit 7: This bit is the Divisor Latch Access Bit (DLAB). It must be set high (logic 1) to access the Divisor Latches of the Baud Generator during a Read or Write operation. It must be set low (logic 0) to access the Receiver Buffer, the Transmitter Holding Register, or the Interrupt Enable Register.

Programmable Baud Rate Generator

The UM8250B contains a programmable Baud Rate Generator that is capable of taking any clock input (DC to 3.1 MHz) and dividing it by any divisor from 1 to $(2^{16}-1)$. The output frequency of the Baud Generator is 16X the Baud rate [divisor \neq (frequency input) \div (baud rate x 16)]. Two 8-bit latches store the divisor in a 16-bit binary format. These Divisor Latches must be loaded during initialization in order to ensure desired operation of the Baud Rate Generator. Upon loading either of the Divisor Latches, a 16-bit Baud counter is immediately loaded. This prevents long counts on initial load.

Tables 4 and 5 illustrate the use of the Baud Generator with crystal frequencies of 1.8432 MHz and 3.072 MHz respectively. For baud rates of 38400 and below, the error obtained is minimal. The accuracy of the desired baud rate is dependent on the crystal frequency chosen. The maximum operating frequency of the Baud Generator is 3.1 MHz. However, when using divisors of 3 and below, the maximum frequency is equal to the divisor in MHz. For example, if the divisor is 1, then the maximum frequency is 1 MHz. In no case should the data rate be greater than 56K Baud.

Table 4. Baud Rates Using 1.8432 MHz Crystal

Desired Baud Rate	Divisor Used to Generate 16 x Clock	Percent Error Difference Between Desired and Actual
50	2304	—
70	1536	—
110	1047	0.026
133.5	857	0.0258
150	768	—
300	384	—
600	192	—
1200	96	—
1800	64	—
2000	58	0.69
2400	48	—
3600	32	—
4800	24	—
7200	16	—
9600	12	—
19200	6	—
38400	3	—
56000	2	2.86

Note: 1.8432 MHz is the standard 8080 frequency divided by 10.



T-75-37-05
UM8250B

Table 5. Baud Rates Using 3.072 MHz Crystal

Desired Baud Rate	Divisor Used to Generate 16 x Clock	Percent Error Difference Between Desired and Actual
50	3840	—
75	2560	—
110	1745	0.026
134.5	1428	0.034
150	1280	—
300	640	—
600	320	—
1200	160	—
1800	107	0.312
2000	96	—
2400	80	—
3600	53	0.628
4800	40	—
7200	27	1.23
9600	20	—
19200	10	—
38400	5	—

Fig. 1 and 2 show the typical application circuits of the UM8250's clock generation.

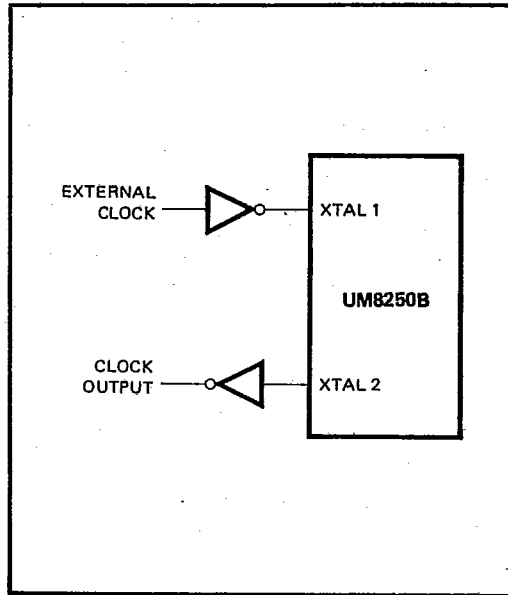

Figure 1. Clock Circuit with External Clock Signal

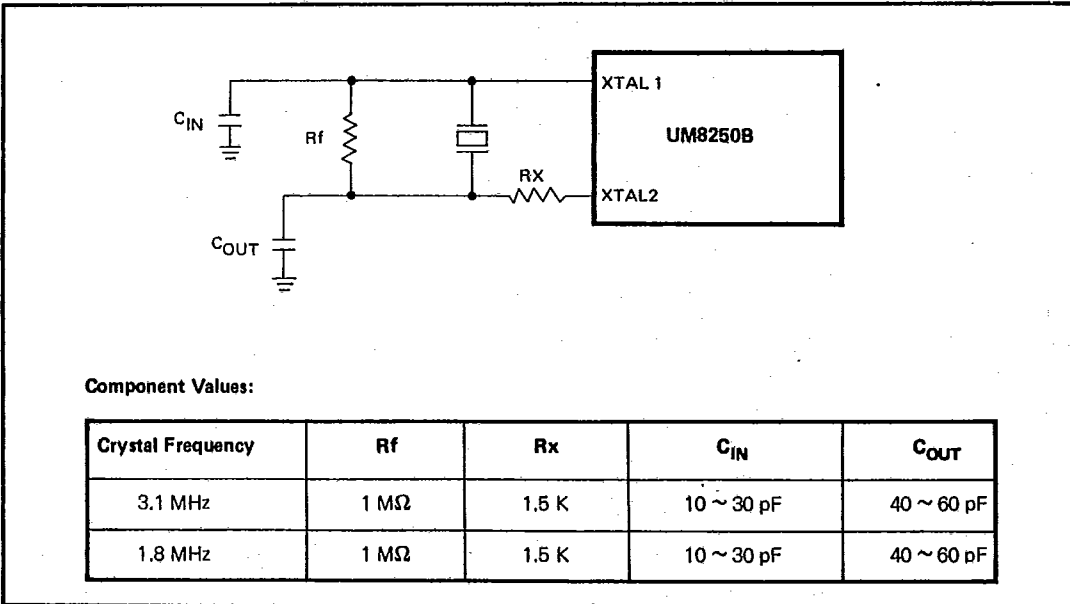

Figure 2. Clock Circuit with Crystal Oscillator

I/O And Peripherals



T-75-37-05

UM8250B

Line Status Register

This 8-bit register provides status information to the CPU concerning the data transfer. The contents of the Line Status Register are indicated in Table 3 and are described below.

Bit 0: This bit is the receiver Data Ready (DR) indicator. Bit 0 is set to a logic 1 whenever a complete incoming character has been received and transferred into the Receiver Buffer Register. Bit 0 may be reset to a logic 0 either by the CPU reading the data in the Receiver Buffer Register or by writing a logic 0 into it from the CPU.

Bit 1: This bit is the Overrun Error (OE) indicator. Bit 1 indicates that data in the Receiver Buffer Register was not read by the CPU before the next character was transferred into the Receiver Buffer Register, thereby destroying the previous character. The OE indicator is reset whenever the CPU reads the contents of the Line Status Register.

Bit 2: This bit is the Parity Error (PE) indicator. Bit 2 indicates that the received data character does not have the correct even or odd parity, as selected by the even-parity-select bit. The PE bit is set to a logic 1 upon detection of a parity error and is reset to a logic 0 whenever the CPU reads the contents of the Line Status Register.

Bit 3: This bit is the Framing Error (FE) indicator. Bit 3 indicates that the received character did not have a valid Stop bit. Bit 3 is set to a logic 1 whenever the Stop bit following the last data bit or parity bit is detected as a zero bit (Spacing level).

Bit 4: This bit is the Break Interrupt (BI) indicator. Bit 4 is set to a logic 1 whenever the received data input is held in the Spacing (logic 0) state for longer than a full word transmission time (that is, the total time of Start bit + data bits + Parity + Stop bits).

*Note: BI and FE are reset whenever the CPU reads the contents of the Line status indicator.

*Note: Bits 1 through 4 are the error conditions that produce a Receiver Line Status interrupt whenever any of the corresponding conditions are detected.

Bit 5: This bit is the Transmitter Holding Register Empty (THRE) indicator. Bit 5 indicates that the UM8250B is

ready to accept a new character for transmission. In addition, this bit causes the UM8250B to issue an interrupt to the CPU when the Transmit Holding Register Empty Interrupt enable is set high. The THRE bit is set to a logic 1 when a character is transferred from the Transmitter Holding Register into the Transmitter Shift Register. The bit is concurrently reset to logic 0 with the loading of the Transmitter Holding Register by the CPU.

Bit 6: This bit is the Transmitter Shift Register Empty (TSRE) indicator. Bit 6 is set to a logic 1 whenever the Transmitter Shift Register is idle. It is reset to logic 0 upon transfer of data from the Transmitter Holding Register to the Transmitter Shift Register. Bit 6 is a read-only bit.

Bit 7: This bit is permanently set to logic 0.

Interrupt Identification Register

The UM8250B has an on-chip interrupt capability that allows flexibility in interfacing popular microprocessors presently available. In order to provide minimum software overhead during data character transfers, the UM8250B prioritizes interrupts into four levels. The four levels of interrupt conditions are as follows: Receiver Line Status (priority 1); Received Data Ready (priority 2); Transmitter Holding Register Empty (priority 3) and Modem Status (priority 4).

Information indicating that a prioritized interrupt is pending and the type of that interrupt is stored in the Interrupt Identification Register (refer to Table 6). The Interrupt Identification Register (IIR), when addressed during chip-select time, freezes the highest priority interrupt pending and no other interrupts are acknowledged until the particular interrupt is serviced by the CPU. The contents of the IIR are indicated in Table 3 and are described below.

Bit 0: This bit can be used in either a hardwired prioritized or polled environment to indicate whether an interrupt is pending. When bit 0 is a logic 0, an interrupt is pending and the IIR contents may be used as a pointer to the appropriate interrupt service routine. When bit 0 is a logic 1, no interrupt is pending and polling (if used) continues.

Bits 1 and 2: These two bits of the IIR are used to identify the highest priority interrupt pending as indicated in Table 6.



Table 6 Interrupt Control Functions

Interrupt Identification Register			Interrupt Set and Reset Functions			
Bit 2	Bit 1	Bit 0	Priority Level	Interrupt Type	Interrupt Source	Interrupt Reset Control
0	0	1	—	None	None	—
1	1	0	Highest	Receiver Line Status	Overrun Error or Parity Error or Framing Error or Break Interrupt	Reading the Line Status Register
1	0	0	Second	Received Data Available	Receiver Data Available	Reading the Receiver Buffer Register
0	1	0	Third	Transmitter Holding Register Empty	Transmitter Holding Register Empty	Reading the IIR Register (if source of interrupt) or Writing into the Transmitter Holding Register
0	0	0	Fourth	MODEM Status	Clear to Send or Data Set Ready or Ring Indicator or Received Line Signal Detect	Reading the MODEM Status Register

Bits 3 through 7: These five bits of the IIR are always set at logic 0.

Interrupt Enable Register

This 8-bit register enables the four types of interrupts of the UM8250B to separately activate the chip interrupt (INTRPT) output signal. It is possible to totally disable the interrupt system by resetting bits 0 through 3 of the Interrupt Enable Register. Similarly, by setting the appropriate bits of this register to a logic 1, selected interrupts can be enabled. Disabling the interrupt system inhibits the Interrupt Identification Register and the active (high) INTRPT output from the chip. All other system functions operate in their normal manner, including the setting of the Line Status and MODEM Status Registers. The contents of the Interrupt Enable Register are indicated in Table 3 and are described below.

Bit 0: This bit enables the Received Data Available Interrupt when set to logic 1.

Bit 1: This bit enables the Transmitter Holding Register Empty Interrupt when set to logic 1.

Bit 2: This bit enables the Receiver Line Status Interrupt when set to logic 1.

Bit 3: This bit enables the MODEM Status Interrupt when set to logic 1.

Bits 4 through 7: These four bits are always set at logic 0.

MODEM Control Register

This 8-bit register controls the interface with the MODEM or data set (or a peripheral device emulating a MODEM). The contents of the MODEM Control Register are indicated in Table 3 and are described below.

Bit 0: This bit controls the Data Terminal Ready (DTR) output. When bit 0 is set to logic 1, the DTR output

I/O And Peripherals



T-75-37-05

UM8250B

is forced to a logic 0. When bit 0 is reset to a logic 0, the \overline{DTR} output is forced to a logic 1. The \overline{DTR} output of the UM8250B may be applied to an EIA inverting line driver (such as the DS1488) to obtain the proper polarity input at the succeeding MODEM or data set.

Bit 1: This bit controls the Request to Send (\overline{RTS}) output. Bit 1 affects the \overline{RTS} output in a manner identical to that described for bit 0.

Bit 2: This bit controls the Output 1 ($\overline{OUT1}$) signal, which is an auxiliary user-designated output. Bit 2 affects the $\overline{OUT1}$ output in a manner identical to that described for bit 0.

Bit 3: This bit controls the Output 2 ($\overline{OUT2}$) signal, which is an auxiliary user-designated output. Bit 3 affects the $\overline{OUT2}$ output in a manner identical to that described for bit 0.

Bit 4: This bit provides a local loopback feature for diagnostic testing of the UM8250B. When bit 4 is set to logic 1, the following occurs: the transmitter Serial Output (SOUT) is set to the Marking (logic 1) state, the receiver Serial Input (SIN) is disconnected, the output of the Transmitter Shift Register is "looped back" into the Receiver Shift Register input, the four MODEM Control inputs (\overline{CTS} , \overline{DSR} , \overline{DCD} , and \overline{RI}) are disconnected, and the four MODEM Control outputs (\overline{DTR} , \overline{RTS} , $\overline{OUT1}$, and $\overline{OUT2}$) are internally connected to the four MODEM Control inputs, and the MODEM Control output pins are forced to their inactive state (high). In the diagnostic mode, data that is transmitted is immediately received. This feature allows the processor to verify the transmit and received-data paths of the UM8250B.

In the diagnostic mode, the receiver and transmitter interrupts are fully operational. The MODEM Control Interrupts are also operational, but the interrupts' sources are now the lower four bits of the MODEM Control Register instead of the four MODEM Control inputs. The interrupts are still controlled by the Interrupt Enable Register.

The UM8250B interrupt system can be tested by writing into the lower six bits of the Line Status Register and the lower four bits of the MODEM Status Register. Setting any of these bits to a logic 1 generates the appropriate interrupt (if enabled). The resetting of these interrupts is the same as in normal UM8250B operation. To return to normal operation, the registers must be reprogrammed for normal operation and then bit 4 of the MODEM control Register must be reset to logic 0.

Bits 5 through 7: These bits are permanently set to logic 0.

MODEM Status Register

This 8-bit register provides the current state of the control lines from the MODEM (or peripheral device) to the CPU. In addition to this current-state information, four bits of the MODEM Status Register provide change information. These bits are set to a logic 1 whenever a control input from the MODEM changes state. They are reset to logic 0 whenever the CPU reads the MODEM Status Register.

The contents of the MODEM Status Register are indicated in Table 3 and are described below.

Bit 0: This bit is the Delta Clear to Send (DCTS) indicator. Bit 0 indicates that the \overline{CTS} input to the chip has changed state since the last time it was read by the CPU.

Bit 1: This bit is the Delta Data Set Ready (DDSR) indicator. Bit 1 indicates that the \overline{DSR} input to the Chip has changed states since the last time it was read by the CPU.

Bit 2: This bit is the Trailing Edge of Ring Indicator (TERI) detector. Bit 2 indicates that the \overline{RI} input to the chip has changed from a low state to a high state.

Bit 3: This bit is the Delta Data Carrier Detector (DDCD) indicator. Bit 3 indicates the \overline{DCD} input to the chip has changed states.

*Note that whenever bit 0, 1, 2 or 3 is set at logic 1, a MODEM Status interrupt is generated.

Bit 4: This bit is the complement of the Clear to Send (\overline{CTS}) input. If bit 4 (loop) of the MCR is set to a 1, this bit is equivalent to \overline{RTS} in the MCR.

Bit 5: This bit is the complement of the Data Set Ready (\overline{DSR}) input. If bit 4 of the MCR is set to a 1, this bit is equivalent to \overline{DTR} in the MCR.

Bit 6: This bit is the complement of the Ring Indicator (\overline{RI}) input. If bit 4 of the MCR is set to a 1, this bit is equivalent to $\overline{OUT1}$ in the MCR.

Bit 7: This bit is the complement of the Data Carrier Detect (\overline{DCD}) input. If bit 4 of the MCR is set to a 1, this bit is equivalent to $\overline{OUT2}$ of the MCR.

T-75-37-05



UM8250B

Ordering Information

Part No.	Package
UM8250B	40L DIP
UM8250BL	44L PLCC

I/O And
Peripherals

This datasheet has been download from:

www.datasheetcatalog.com

Datasheets for electronics components.