

ONE-CHIP TAPE RECORDER SYSTEM

The KA2213 is a monolithic integrated circuit consisting of a preamplifier, ALC circuit, power amplifier in a 14-pin plastic dual in line package with heat sink.

14 DIP H/S

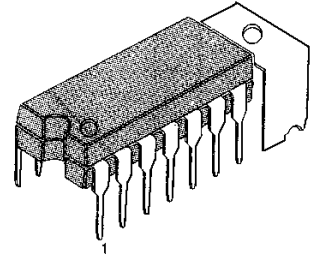

FEATURES

- Suitable for the play and recording functions of mono cassette tape recorders.
- Wide operating supply voltage range: $V_{CC} = 4V \sim 12V$
- High gain preamplifier and power amplifier.
- Output power of power amplifier state $P_O = 1W$ at $V_{CC} = 6V$, $R_L = 4\Omega$, THD= 10%.
- Soft tone quality at the time of output saturation.
- Wide ALC range and small variation in output voltage.
- Small shock noise at the time of power on/off due to built-in prevention circuit.
- Variable monitor capability due to recording amplifier consisting of preamplifier alone.
- Minimum number of external parts required.

ORDERING INFORMATION

Device	Package	Operating Temperature
KA2213	14 DIP H/S	-20°C ~ +70°C

BLOCK DIAGRAM

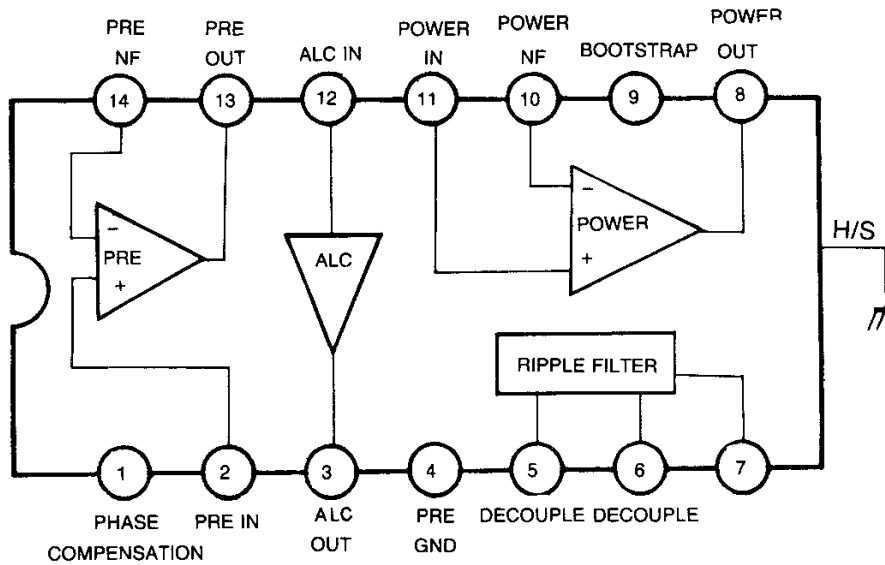

ABSOLUTE MAXIMUM RATINGS (T_a = 25°C)

Characteristic	Symbol	Value	Unit
Supply Voltage	V _{CC}	13	V
Power Dissipation	P _D	1.2 2.25*	W
Operating Temperature	T _{OPR}	-20 ~ +70	°C
Storage Temperature	T _{STG}	-40 ~ +150	°C

* Mounted and soldered on a 50mm x 50mm copper foil of PCB

ELECTRICAL CHARACTERISTICS

(T_a = 25°C, V_{CC} = 6V, f = 1KHz, unless otherwise specified)

Characteristic	Symbol	Test Conditions	Min	Typ	Max	Unit
Quiescent Circuit Current	I _{CCQ}	V _{CC} = 6V, V _I = 0		18	30	mA
		V _{CC} = 9V, V _I = 0		23	40	mA
Pre Amplifier						
Open Loop Voltage Gain	G _{VO}	Open loop		85		dB
Closed Loop Voltage Gain	G _{VC}	Closed loop, Play		40		dB
Output Voltage	V _O	THD=1%, Play	0.9	1.2		V
Input Resistance	R _I		21	30		KΩ
Equivalent Input Noise Voltage	V _{NI}	Play		1.0	2.0	μV
ALC Input Level	V _{I(ALC)}	THD = 1%, Rec	-20	-12		dBm
Power Amplifier						
Closed Loop Voltage Gain	G _{VC}	R _F = 51Ω	43	45	47	dB
Output Power	P _O	V _{CC} = 6V, R _L = 4Ω, THD=10%	0.7	1.0		W
		V _{CC} = 7.5V, R _L = 4Ω, THD=10%	1.0	1.5		W
		V _{CC} = 9V, R _L = 4Ω, THD=10%	1.7	2.2		W
Total Harmonic Distortion	THD	P _O = 250mW		0.3	1.5	%
Input Resistance	R _I			30		KΩ
Output Noise Voltage	V _{NO}	R _G = 10KΩ		0.6	1.8	mV
Ripple Rejection Ratio	RR	R _G = 0Ω, V _R = 150mV, f = 100Hz	40	45		dB

TEST CIRCUIT

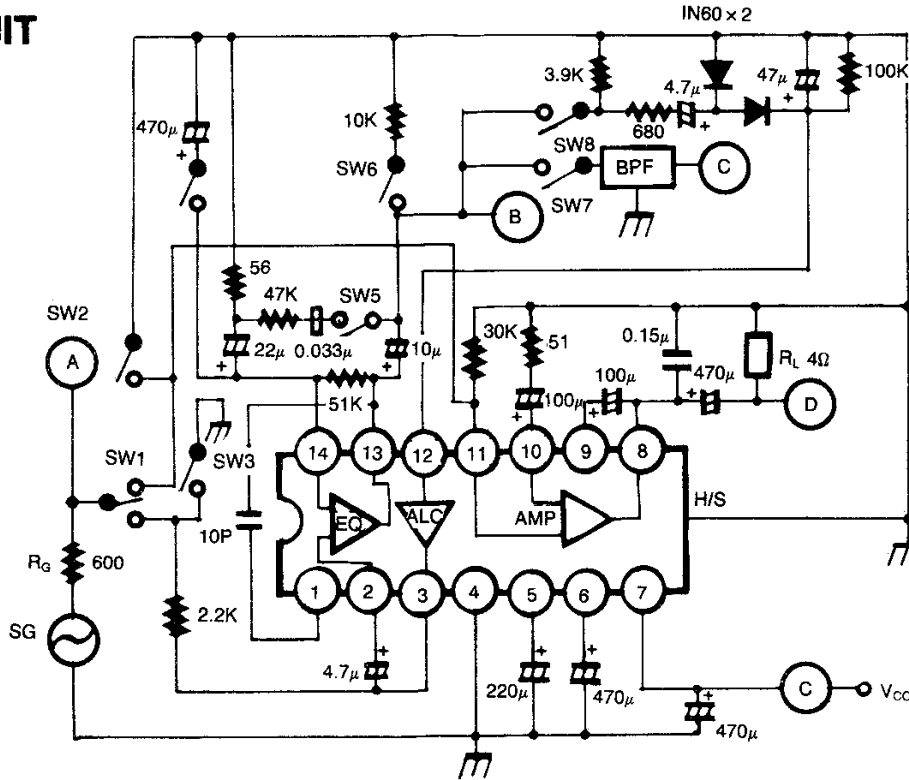

Fig. 2

TEST METHOD

	Characteristic	SW1	SW2	SW3	SW4	SW5	SW6	SW7	SW8	Test Point	Test Method
Power Amplifier	I _{CCQ}		on	on	off	on	on	off	off		Test circuit current
	G _{VC}	2	off	off	off	on	on	off	off	A.D	G _{VC} = 20 log V _O /V _I (dB)
	P _O	2	off	off	off	on	on	off	off	D	Test output voltage at THD = 10%
	THD	2	off	off	off	on	on	off	off	D	Test THD at output voltage V _O = 1V
	V _{NO}		on	off	off	on	on	off	off	D	Test output noise voltage
	RR		on	off	off	on	on	off	off	D	RR = 20 log V _{RO} /150 (dB) Test output ripple voltage (V _{RO})
Pre-Amplifier	G _{VO}	1	off	off	on	off	on	off	off	A.B	G _{VO} = 20 log V _O /V _I (dB)
	V _O	1	off	off	off	on	on	off	off	B	Test output voltage at THD = 1%
	V _{NI}		off	on	off	on	on	on	off	C	Convert output noise voltage at R _G = 2.2KΩ, V _{NI} = V _{NO} /G _V
	V _{I(ALC)}	1	off	off	off	off	off	off	on	A.B	Test input voltage at THD = 1%

TYPICAL APPLICATION CIRCUITS

1. Mono cassette tape recorder

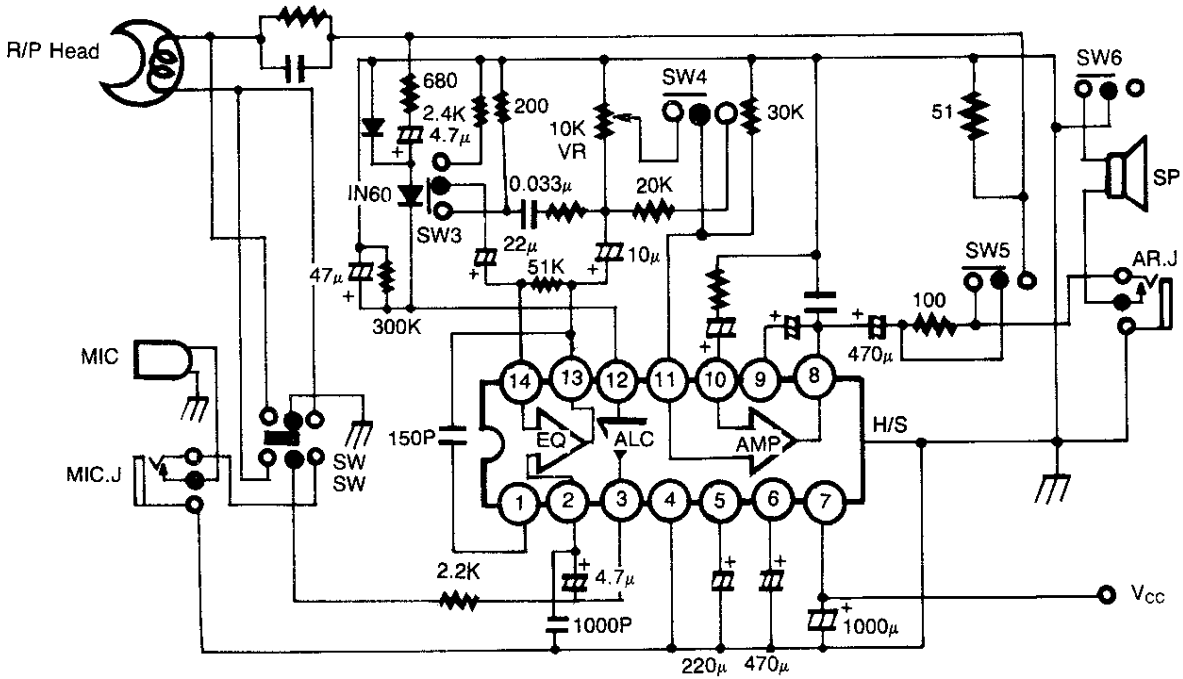

Fig. 3

2. Radio cassette tape recorder

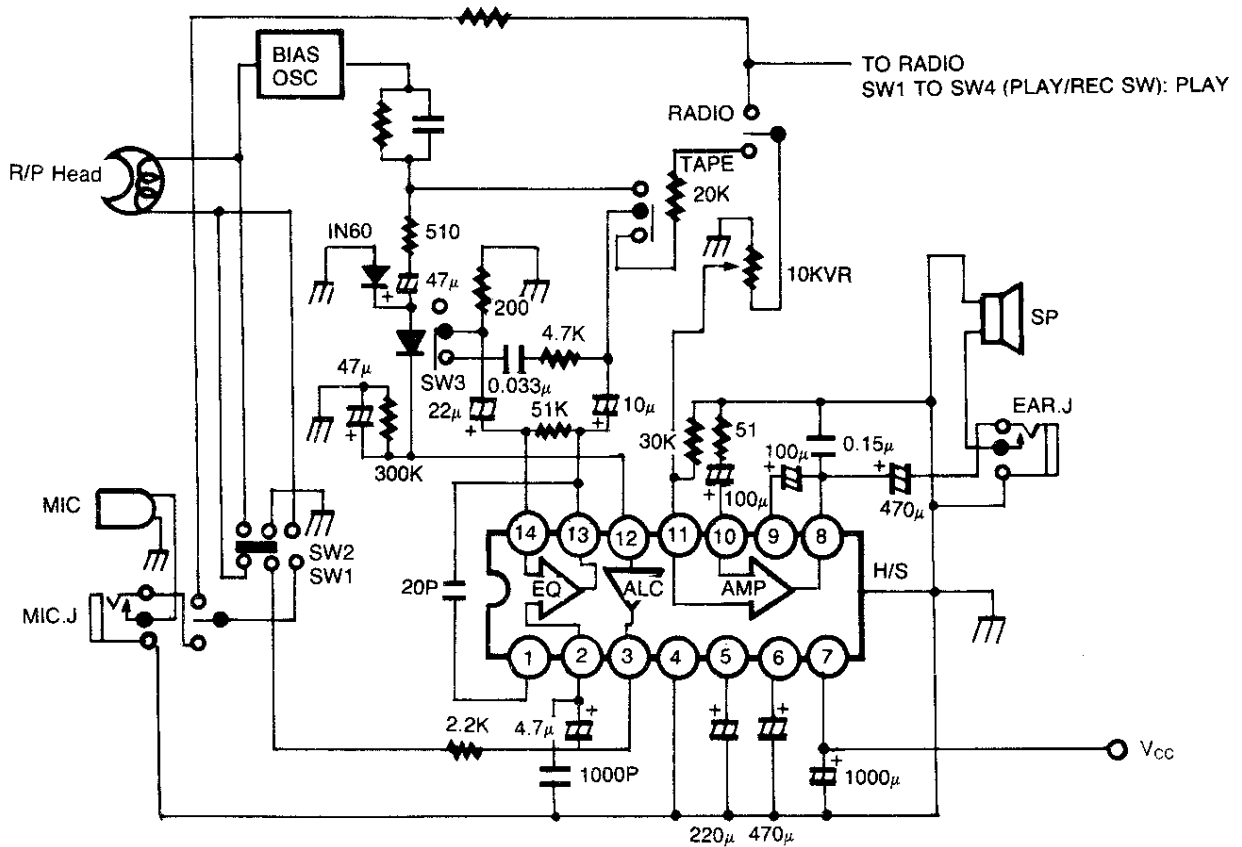

Fig. 4

This datasheet has been download from:

www.datasheetcatalog.com

Datasheets for electronics components.