

SPEC NO.: D100-181119

Specification

TO:STE508

Model Name: Crystal Unit

PART NO: TA6CS-12.000M-15-20-20-A

CUSTOMER PART NO.:

Approval sheet:

| | |
|--|-------------|
| Approved | Yes |
| | No. |
| Customer's comments are welcomed here. | |
| Pls return this copy as a certificate of your approval by Email. | |
| Approved By | Date: _____ |

STRONG ELECTRONICS&TECHNOLOGY LIMITED

Service Hotline:86-755-84528985 Fax: 86-755-84528986

Email:info@strongfirst.com.cn

www.strongfirst.com.cn

History Record

| Date | Part No. | SPEC No. | Description. | Remarks. |
|--|-------------------------------|---------------------|--------------------|--------------------|
| 2018-11-17 | | | Initial issue | |
| | | | | |
| | | | | |
| | | | | |
| | | | | |
| | | | | |
| | | | | |
| | | | | |
| | | | | |
| | | | | |
| | | | | |
| | | | | |
| | | | | |
| <div style="background-color: #008000; color: white; padding: 2px; font-size: 8px;"> RoHS Compliant Lead free Lead-free soldering </div> | ISO9001:2000 ISO14001:2004 | Approved by | Check by | Design by |
| | | Nov-17-2018 | NOV-17-2018 | NOV-17-2018 |
| Reversions | Total Page | <i>Xu gang dong</i> | <i>Liu jun</i> | <i>Wang kon</i> |

1. RANGE:

This specification shall cover the characteristics of the SMD quartz crystal unit with the type TA6CS-12.000M-15-20-20-A.

2. PART NO.

| | |
|--------------------------|----------------------|
| PART NUMBER | PREVIOUS PART NUMBER |
| TA6CS-12.000M-15-20-20-A | |
| CUSTOMER PART NO | SPECIFICATION NO |
| | |

3. OUTLINE DIMENSIONS AND MARK

3.1 Appearance: No visible damage and dirt.

3.2 Construction: SMD ceramic packaged.

3.3 The products conform to the RoHS directive and national environment protection law.

3.4 Dimensions and mark

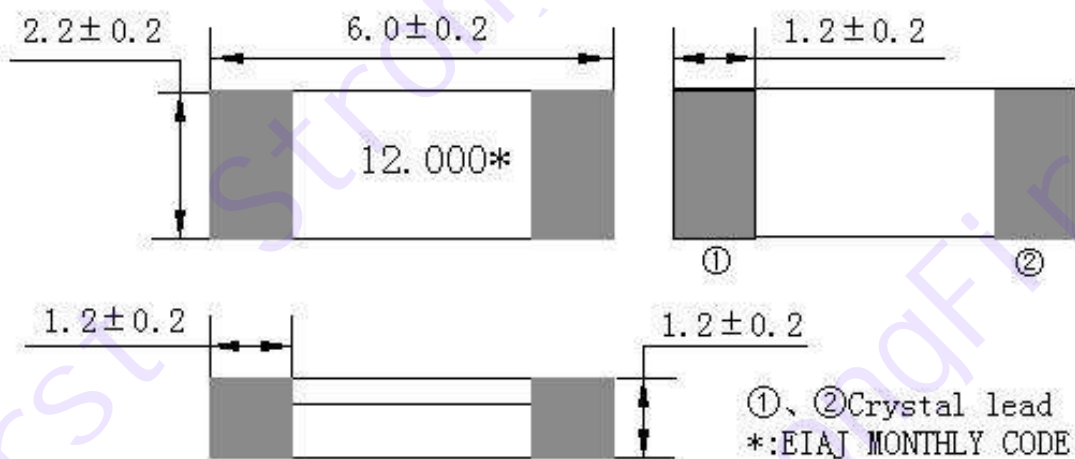

4. ELECTRICAL SPECIFICATIONS

4.1 RATING

| Items | Requirement |
|---|------------------|
| Insulation Resistance ($M \Omega$) min. | 500 (at DC 100V) |
| Operating Temperature Range ($^{\circ}C$) | -20 ~ 70 |
| Storage Temperature Range ($^{\circ}C$) | -40 ~ 85 |

4.2 ELECTRICAL SPECIFICATIONS

| Items | Requirement |
|--|---|
| Nominal Frequency (MHz) | 12.000 |
| Frequency Tolerance (ppm) | ± 20 (at $25^{\circ}C$) |
| Temperature Stability (Ref. To $25^{\circ}C$) (PPM) | ± 20 ($-20^{\circ}C \sim 70^{\circ}C$) |
| Mode of Oscillation | Fundamental |
| Shunt Capacitance C_0 (pF) max. | 7 |
| Load Capacitance C_L (pF) | 15 |
| Equivalent Series Resistance (Ω) max. | 60 |
| Drive Level (μW) max. | 100 |
| Aging (PPM/year) max. | ± 10 (at $25^{\circ}C$) |

5. TEST

5.1 Test Conditions

Parts shall be tested under the condition (Temp.: $20 \pm 15^{\circ}C$, Humidity : $65 \pm 20\%$ R.H.) unless the standard condition (Temp.: $25 \pm 2^{\circ}C$, Humidity : $65 \pm 5\%$ R.H.) is regulated to measure.

6 PHYSICAL AND ENVIRONMENTAL CHARACTERISTICS

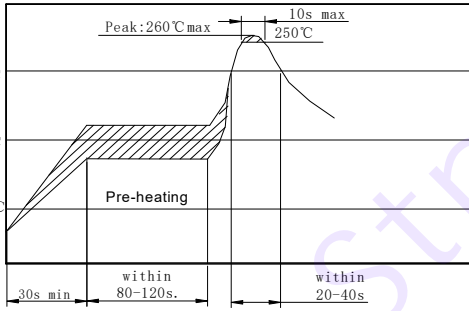
| No | Item | Condition of Test | Performance Requirements |
|-----|------------------------------|---|---|
| 6.1 | Humidity Test | Stored in 90% ~ 95% R.H. at 40 °C ± 2 °C for 500h, and left at room temperature for 1h before measurement. | It shall fulfill the specifications in Table 1. |
| 6.2 | High Temp. Storage | Stored in 85 ± 2 °C for 500h, and left at room temperature for 1h before measurement. . | It shall fulfill the specifications in Table 1. |
| 6.3 | Low Temp. Storage | Stored in -40 ± 2 °C for 500h, and left at room temperature for 1h before measurement. | It shall fulfill the specifications in Table 1. |
| 6.4 | Temperature Cycling | Subject the Crystal Unit to - 25 °C for 30 min. followed by a high temperature of 85 °C for 30 min. Cycling shall be repeated 5 times, and left at room temperature for 1h before measurement. | It shall fulfill the specifications in Table 1. |
| 6.5 | Vibration Test | Apply the vibration of sweep frequency (10 ~ 55)Hz/min, amplitude 0.75mm, duration 30 min in each direction of 3 planes | It shall fulfill the specifications in Table 1. |
| 6.6 | Drop Test | Free drop to the wooden plate from 0.75m height for 2 times. | No visible damage and it shall fulfill Table 1. |
| 6.7 | Resistance to Soldering Heat | <p>Passed through the reflow oven under the following condition, and left at room temperature for 1 hour before measurement.</p>  <p>The graph shows a temperature profile for reflow soldering. The y-axis represents temperature in °C, with markers at 100, 150, and 230. The x-axis represents time. The profile starts at 100°C, rises to a peak of 260°C (labeled 'Peak: 260°C max'), and then cools down to 250°C. A 'Pre-heating' phase is indicated between 100°C and 150°C. Time constraints are shown: 30s min for the initial rise, 'within 80-120s.' for the pre-heating phase, and 'within 10s max' for the cooling phase from the peak to 250°C. A final cooling phase is labeled 'within 20-40s'.</p> | It shall fulfill the specifications in Table 1. |

6 PHYSICAL AND ENVIRONMENTAL CHARACTERISTICS(To be continued)

| | | | |
|-----|-------------------------------------|---|---|
| 6.8 | Solder ability | Dipped in $235^{\circ}\text{C} \pm 5^{\circ}\text{C}$ solder bath for $3\text{s} \pm 0.5\text{s}$ with rosin flux (25wt% ethanol solution). | The terminals shall be at least 95% covered by solder |
| 6.9 | Terminal Strength And Bending board | <p>Mount on a glass-epoxy board (100mm×50mm ×1.6mm),then bend it to 1mm diaplacement and keep it for 5s.(See the following figure)</p>  | No visible damage and it shall fulfill the specifications in Table 1. |

Table 1

| Item | Specification after test |
|---|--------------------------|
| Frequency Tolerance at 25°C (ppm) | ± 50 |
| Equivalent Series Resistance(Ω)max | 120 |

**7 RECOMMENDED LAND PATTERN AND REFLOW SOLDERING
STANDARD CONDITIONS**

7.1 Recommended land pattern

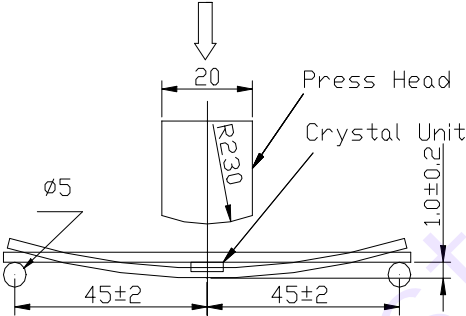
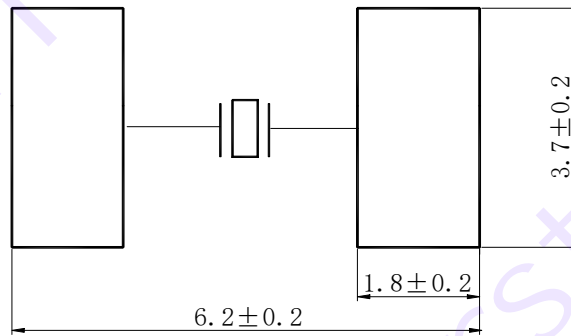

7.2 Recommended reflow soldering standard conditions

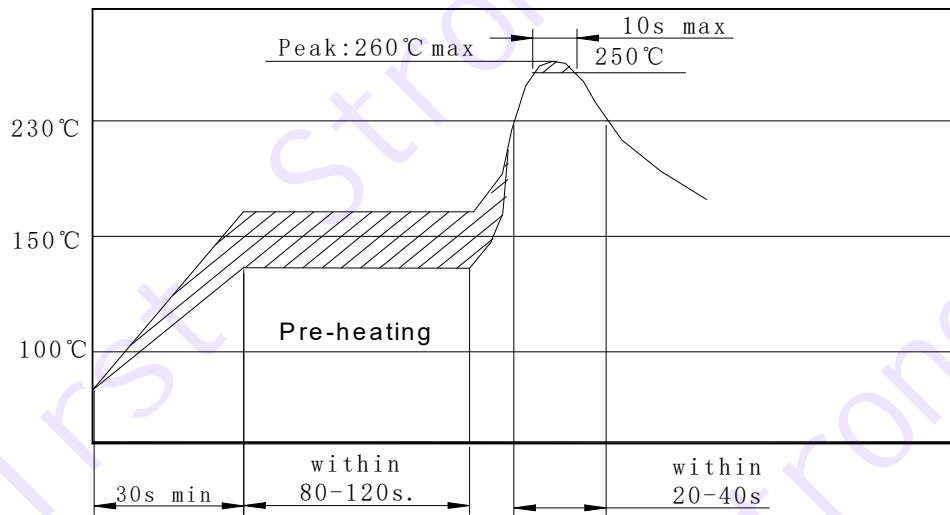

8. PACKAGE

To protect the products in storage and transportation, it is necessary to pack them (outer and inner package) .

8.1 On paper pack, the following requirements are requested.

8.1.1 Dimensions and Mark

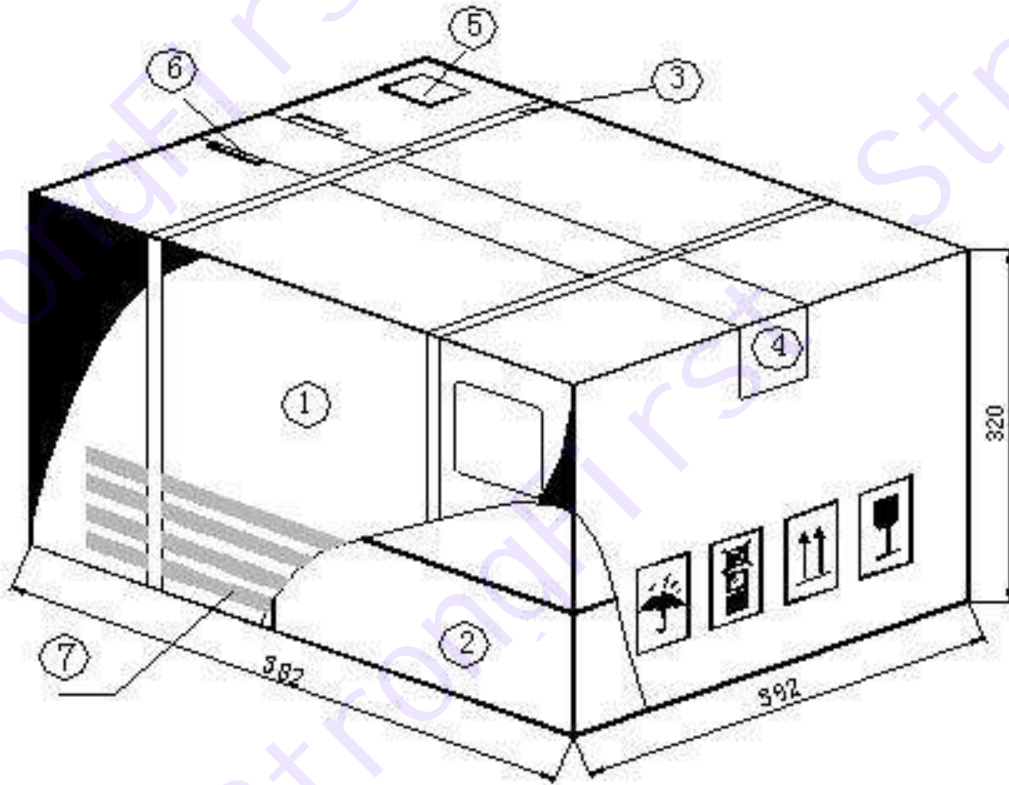

| NO. | Name | Quantity |
|-----|----------------------------|----------|
| ① | Package | 1 |
| ② | Inner Box | 12 |
| ③ | Belt | 2.9 m |
| ④ | Adhesive tape | 1.2 m |
| ⑤ | Label | 1 |
| ⑥ | Certificate of approval | 1 |
| ⑦ | Company name ,Address etc. | |

8.1.2 Section of package

Package is made of corrugated paper with thickness of 0.8cm.Package has 12 inner boxes, each box has 4 reels (each reel for plastic bag).

8.1.3 Quantity of package

Per plastic reel 1000 pieces of SMD part
 Per inner box 4 reels
 Per package 12 inner boxes
 (48000 pieces of SMD quartz crystal unit)

8.1.4 Inner Box Dimensions

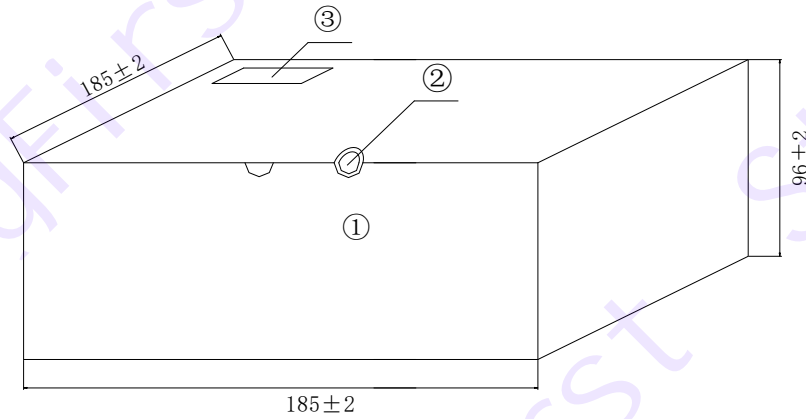

| NO. | Name | Quantity |
|-----|-----------|----------|
| ① | Inner Box | 1 |
| ② | QC Label | 1 |
| ③ | Label | 1 |

8.2 On reel pack, the following requirements are requested.

8.2.1 Reel

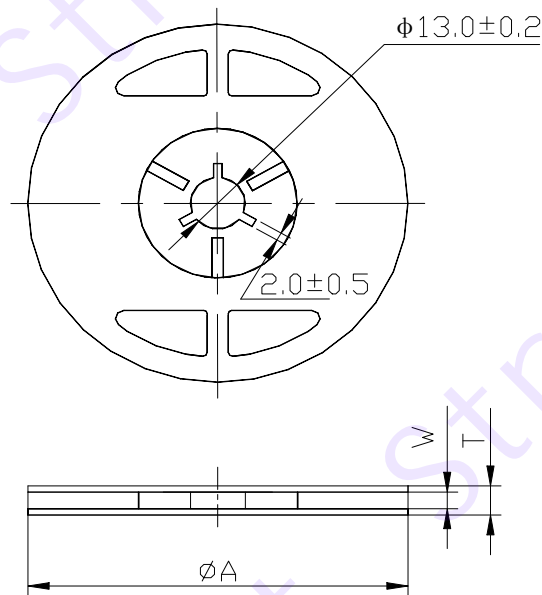

| ϕA | W | T | Pieces per reel | Carrier tape size |
|-------------|---------|---------|-----------------|-------------------|
| 180 ± 3 | 16.4min | 22.4max | 1000typ. | 16 |

8.2.3 Packing Method Sketch Map

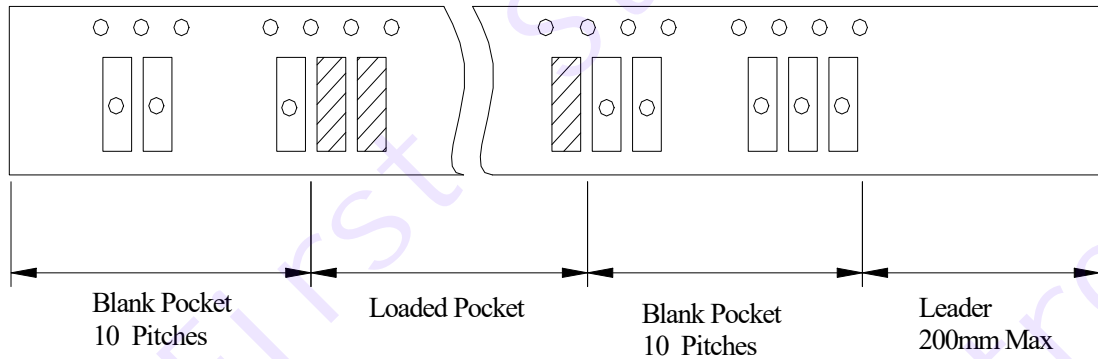

8.2.4 Test Condition Of Peeling Strength

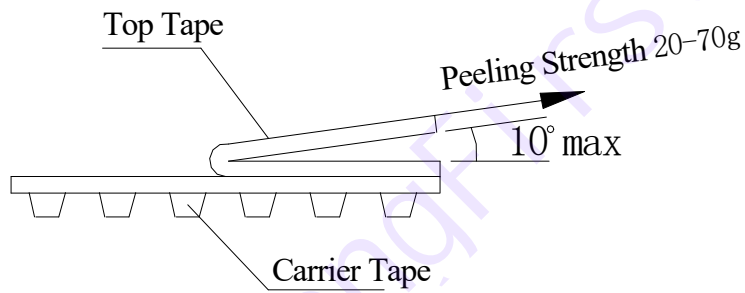

9. EIAJ Monthly Code

| 2011/2013/2015/2017 | | 2010/2012/2014/2016 | |
|---------------------|------|---------------------|------|
| MONTH | CODE | MONTH | CODE |
| JAN | A | JAN | N |
| FEB | B | FEB | P |
| MAR | C | MAR | Q |
| APR | D | APR | R |
| MAY | E | MAY | S |
| JUN | F | JUN | T |
| JUL | G | JUL | U |
| AUG | H | AUG | V |
| SEP | J | SEP | W |
| OCT | K | OCT | X |
| NOV | L | NOV | Y |
| DEC | M | DEC | Z |

10. OTHER

10.1 Caution

10.1.1 Don't apply excess mechanical stress to the component and terminals at soldering. Do not use this product with bend.

10.1.2 Do not use strong acidity flux, more than 0.2wt% chlorine content, in flow soldering.

10.1.3 Don't be close to fire.

10.1.4 This specification mentions the quality of the component as a single unit. Please insure the component is thoroughly evaluated in your application circuit

10.1.5 Expire date (Shelf life) of the products is six months after delivery under the conditions of a sealed and an unopened package. Please use the products within six months after delivery. If you store the products for a long time (more than six months), use carefully because the products may be degraded in the solder ability or rusty. Please confirm solder ability and characteristics for the products regularly.

10.1.6 Please contact us before using the product as automobile electronic component.

10.2 Notice

10.2.1 Please return one of this specification after your signature of acceptance.

10.2.2 When something gets doubtful with this specifications, we shall jointly work to get an agreement.

[© Copyright 2019 StrongFirst, All Rights Reserved](#)