



SHOULDER

SHOULDER ELECTRONICS CO., LTD

SPECIFICATION FOR APPROVAL

NO 编号: _____

CUSTOMER 客 户: _____

PRODUCT 产 品: _____ SAW FILTER

MODEL NO 型 号: _____ HDF869AN-S4

PREPARED 编 制: _____ Fengyu CHECKED 审 核: _____ York

APPROVED 批 准: _____ Lijiating DATE 日 期: _____ 2006-5-11

CUSTOMER 客户确认意见:

CHECKED 审 核:

APPROVED 批 准:

DATE 日 期:

公司地址: 广东深圳市福田区车公庙泰然工业区 303 栋 5 楼西座
West 5/F, 303 Bldg., Che Gong Miao, Industry Park, Futian
Dist., Shenzhen, Guangdong, China.

Tel: 86-755-82916880 Fax: 86-755-82916881

工厂地址: 江苏无锡市滨湖经济技术开发区高运路 115 号

No. 115, Gaoyun road, Binhu Economic&Technology Development
Area, Wuxi, Jiangsu, China

Tel: 86-510-5629111 Fax: 86-510-5627222

[Website: www.shoulder.cn](http://www.shoulder.cn)

1. Package Dimension

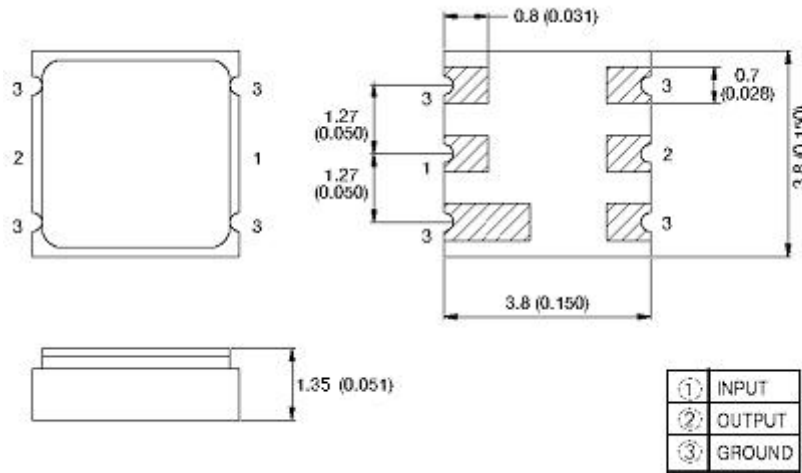

2. Marking HDF 4803

- 2.1 Color: Black or Blue
- 2.2 869.: Center Frequency(MHz)

3. Performance

- 3.1 Application
Low-Loss SAW Filter of cordless system.
Center Frequency:869 MHz
- 3.2 Maximum Rating

Operation Temperature Range	-40°C to +85°C
Storage Temperature Range	-40°C to +85°C
DC. Permissive Voltage	5 V DC. max.
Maximum Input Power	15dBm

3.3 Electronic Characteristics

Item	Frequency	Specification
Center Frequency(F_o)	869MHz	
Pass Band Width	$F_o \pm 1.0\text{MHz}$	
Insertion Loss	Passband	4.5dB max.
Stop Band Rejection	$F_o - 400 \sim -40.8\text{MHz}$ $F_o + 50 \sim +400\text{MHz}$	40dB min. 40dB min.
Terminating Impedance		50 Ω

3.4 Frequency Characteristics

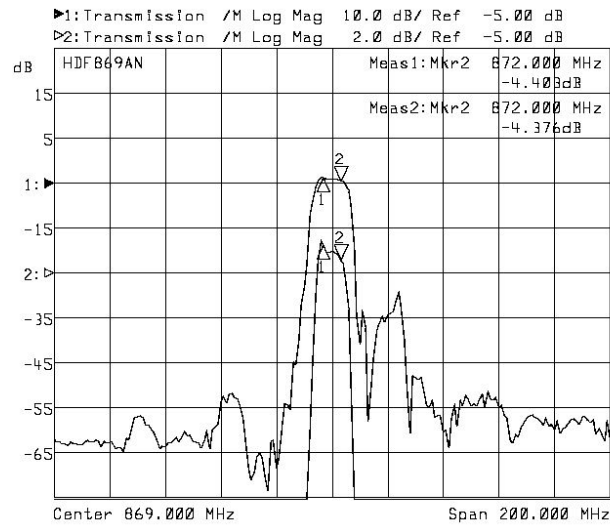

3.5 Test Circuit

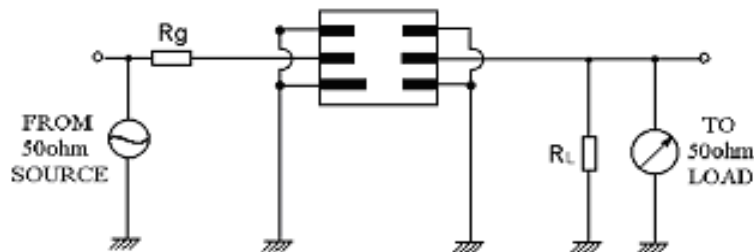

4. ENVIRONMENTAL CHARACTERISTICS

4-1 Temperature cycling

Subject the device to a low temperature of -40°C for 30 minutes. Following by a high temperature of $+25^{\circ}\text{C}$ for 5 Minutes and a higher temperature of $+85^{\circ}\text{C}$ for 30 Minutes. Then release the device into the room conditions for 1 to 2 hours prior to the measurement. It shall meet the specifications in table 1.

4-2 Resistance to solder heat

Submerge the device terminals into the solder bath at $260^{\circ}\text{C} \pm 5^{\circ}\text{C}$ for 10 ± 1 sec. Then release the device into the room conditions for 4 hours. It shall meet the specifications in table 1.

4-3 Solderability

Submerge the device terminals into the solder bath at $245^{\circ}\text{C} \pm 5^{\circ}\text{C}$ for 5s, More than 95% area of the soldering pad must be covered with new solder. It shall meet the specifications in table 1.

4-4 Mechanical shock

Drop the device randomly onto the concrete floor from the height of 1 m 3 times. the filter shall fulfill the specifications in table 1.

4-5 Vibration

Subject the device to the vibration for 2 hour each in x,y and z axes with the amplitude of 1.5 mm at 10 to 55 hz. The filter shall fulfill the specifications in table 1.

5. REMARK

5.1 Static voltage

Static voltage between signal load & ground may cause deterioration & destruction of the component. Please avoid static voltage.

5.2 Ultrasonic cleaning

Ultrasonic vibration may cause deterioration & destruction of the component. Please avoid ultrasonic cleaning

5.3 Soldering

Only leads of component may be soldered. Please avoid soldering another part of component.

6. Packing

6.1 Dimensions

- (1) Carrier Tape: Figure 1
- (2) Reel: Figure 2
- (3) The product shall be packed properly not to be damaged during transportation and storage.

6.2 Reeling Quantity

1000 pcs/reel	7''
3000 pcs/reel	13''

6.3 Taping Structure

- (1) The tape shall be wound around the reel in the direction shown below.

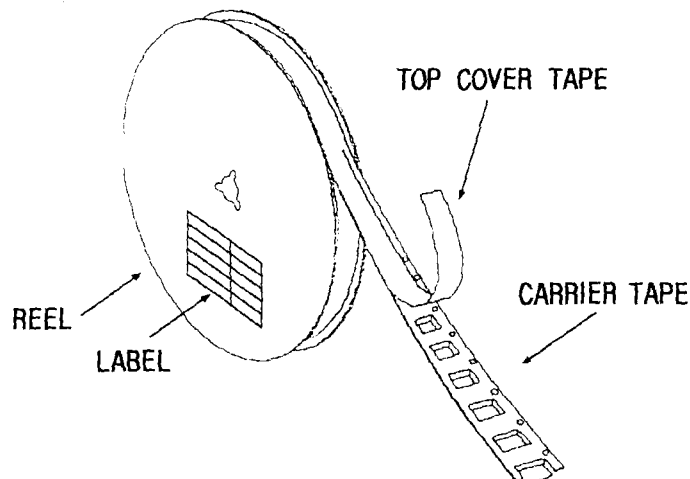

(2) Label

Device Name	
User Product Name	
Quantity	
Lot No.	

(3) Leader part and vacant position specifications.

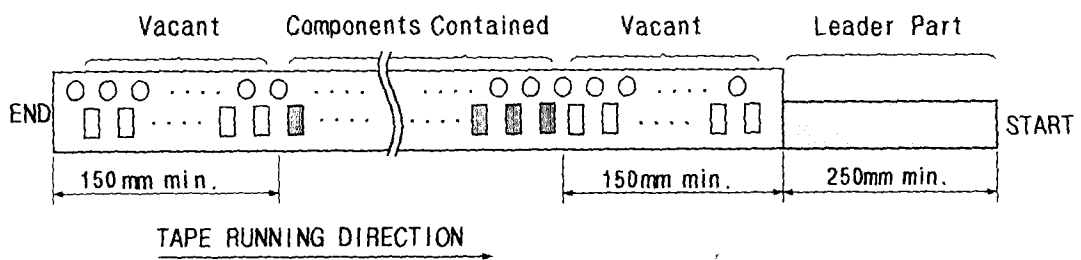

7. TAPE SPECIFICATIONS

7.1 Tensile Strength of Carrier Tape: 4.4N/mm width

7.2 Top Cover Tape Adhesion (See the below figure)

- (1) pull off angle: 0~15°
- (2) speed: 300mm/min.
- (3) force: 20~70g

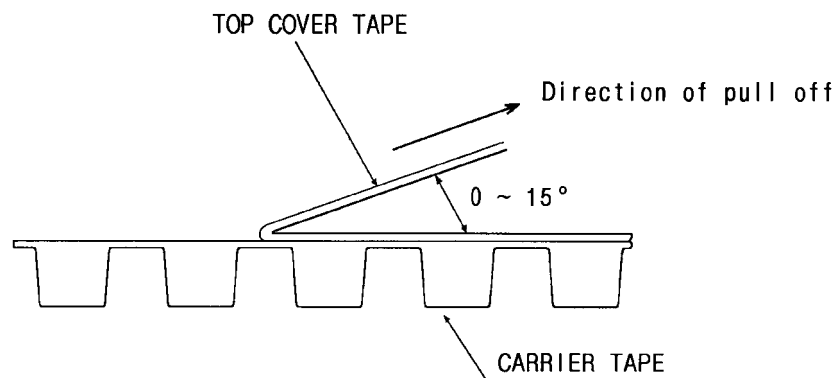

[Figure 1] Carrier Tape Dimensions

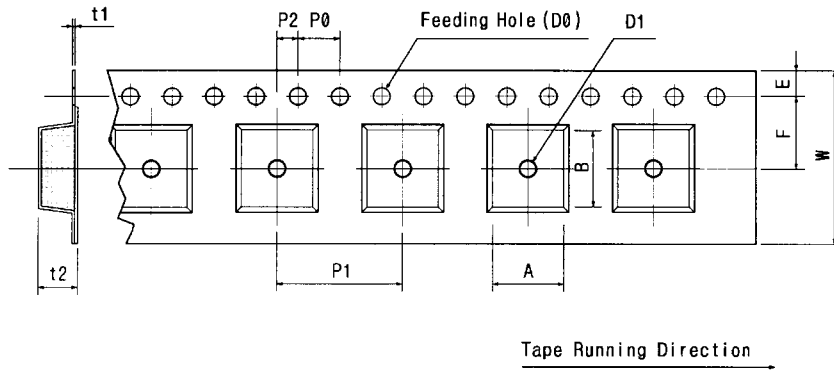

[Unit:mm]

W	F	E	P0	P1	P2	D0	D1	t1	t2	A	B
12.00	5.50	1.75	4.00	8.00	2.00	Ø1.50	Ø1.0	0.25	1.65	4.04	4.10
±0.30	±0.10	±0.10	±0.10	±0.10	±0.10		±0.25	±0.05	±0.10	±0.10	±0.10

[Figure 2]

[Unit:mm]

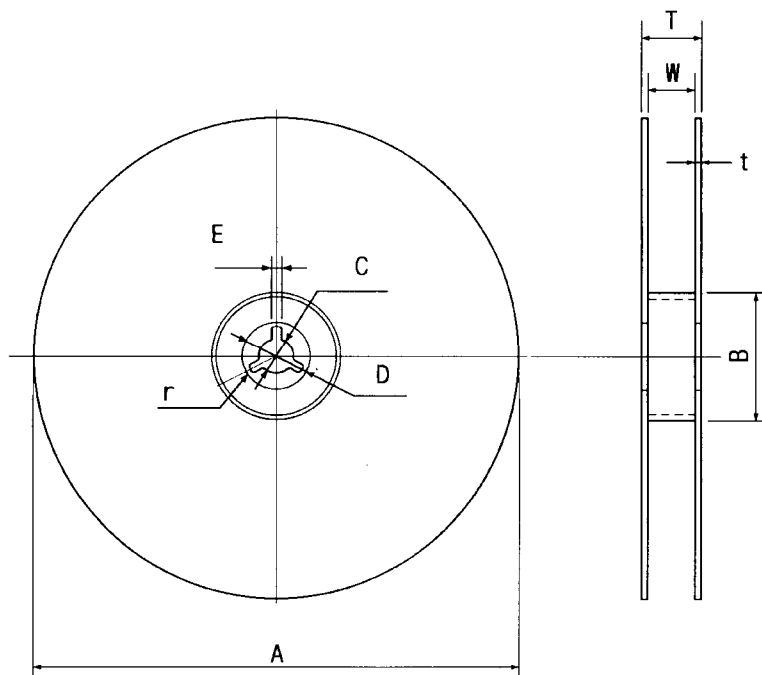

A	B	C	D	E	W	t	r
Ø330	Ø100	Ø13	Ø21	2	13	3	1.0
±1.0	±0.5	±0.5	±0.8	±0.5	±0.3	max.	max.