

规格书编号

SPEC NO :

# 产品规格书

# SPECIFICATION

CUSTOMER 客户: \_\_\_\_\_

PRODUCT 产品: \_\_\_\_\_ SAW RESONATOR

MODEL NO 型号: \_\_\_\_\_ HDR360M-D11

PREPARED 编制: \_\_\_\_\_ CHECKED 审核: \_\_\_\_\_

APPROVED 批准: \_\_\_\_\_ DATE 日期: \_\_\_\_\_ 2012-12-26

客户确认 CUSTOMER RECEIVED:		
审核 CHECKED	批准 APPROVED	日期 DATE

无锡市好达电子有限公司  
Shoulder Electronics Limited



## 1. SCOPE

This specification is applied to a SAW resonator designed for the stabilization of transmitters such as garage door openers and security transmitters.

## 2. ELECTRICAL SPECIFICATION

DC Voltage VDC	30V
AC Voltage Vpp	10V50Hz/60Hz
Operation temperature	-40°C to +85°C
Storage temperature	-45°C to +85°C
RF Power Dissipation	0dBm

### 2.2 Electronic Characteristics

Item	Unites	Minimum	Typical	Maximum	
Center Frequency	MHz	359.925	360.000	360.075	
Insertion Loss	dB		1.5	2.2	
Quality Factor Unload Q		6000	10000		
50Ω Loaded Q		1000	2000		
Temperature Stability	Turnover Temperature	°C	10	25	40
	Freq.temp.Coefficient	ppm/°C <sup>2</sup>		0.032	
Frequency Aging		ppm/yr		<±10	
DC. Insulation Resistance	MΩ	1.0			
RF Equivalent RLC Model	Motional Resistance R1	Ω		22	26
	Motional Inductance L1	μ H		118.43	
	Motional Capacitance C1	fF		1.6503	
Transducer Static Capacitance	pF		2.2		

## 3. TEST CIRCUIT

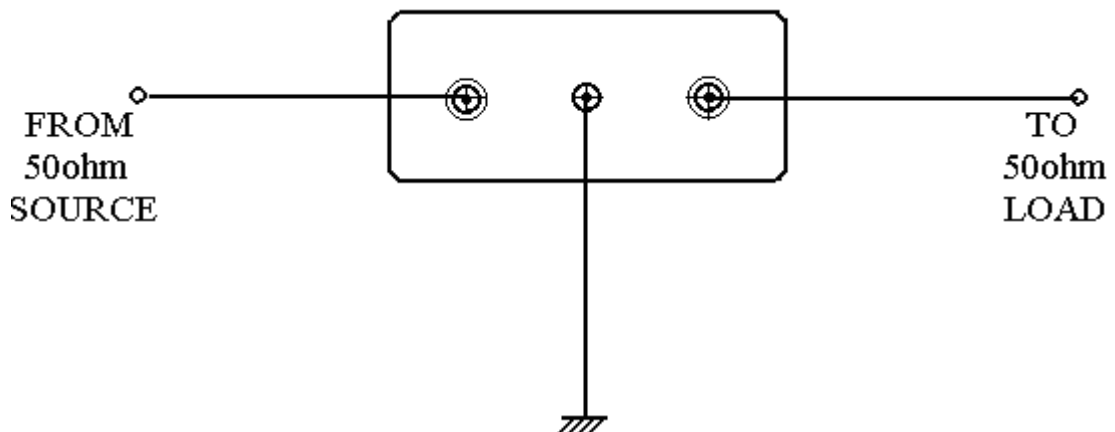

#### 4. DIMENSION

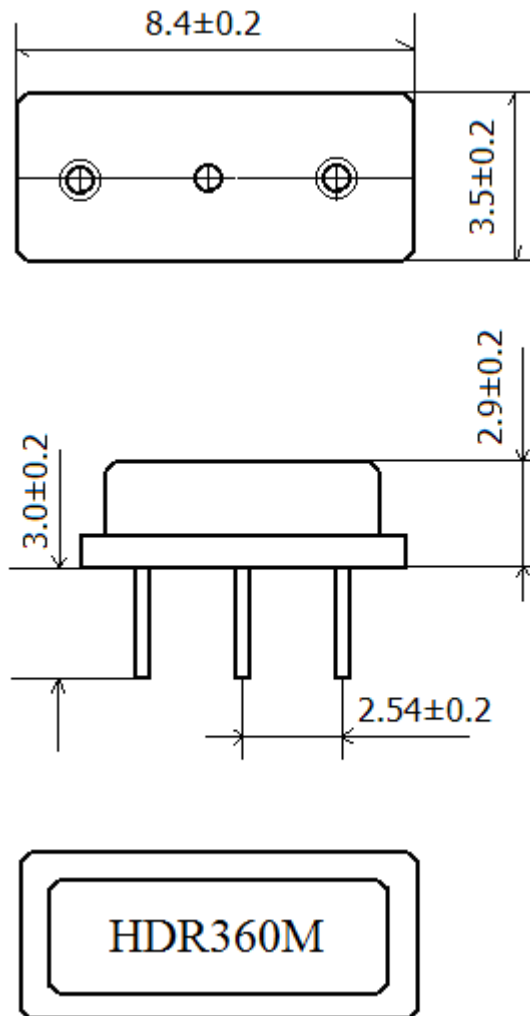

#### 5. ENVIRONMENTAL CHARACTERISTICS

##### 5-1 High temperature exposure

Subject the device to  $+85^{\circ}\text{C}$  for 16 hours. Then release the resonator into the room conditions for 24 hours prior to the measurement. It shall fulfill the specifications in 2.2.

##### 5-2 Low temperature exposure

Subject the device to  $-40^{\circ}\text{C}$  for 16 hours. Then release the device into the room conditions for 24 hours prior to the measurement. It shall fulfill the specifications in 2.2.

##### 5-3 Temperature cycling

Subject the device to a low temperature of  $-40^{\circ}\text{C}$  for 30 minutes. Following by a high temperature of  $+85^{\circ}\text{C}$  for 30 Minutes. Then release the device into the room conditions for 24 hours prior to the measurement. It shall meet the specifications in 2.2.

##### 5-4 Resistance to solder heat

Dip the device terminals no closer than 1.5mm into the solder bath at  $260^{\circ}\text{C} \pm 10^{\circ}\text{C}$  for  $10 \pm 1$  sec. Then release the device into the room conditions for 4 hours. The device shall

meet the specifications in 2.2.

#### 5-5 Solderability

Subject the device terminals into the solder bath at  $245^{\circ}\text{C} \pm 5^{\circ}\text{C}$  for 5s, More than 95% area of the terminals must be covered with new solder. It shall meet the specifications in 2.2.

#### 5-6 Mechanical shock

Drop the device randomly onto the concrete floor from the height of 1m 3 times. the device shall fulfill the specifications in 2.2.

#### 5-7 Vibration

Subject the device to the vibration for 1 hour each in x,y and z axes with the amplitude of 1.5 mm at 10 to 55 Hz. The device shall fulfill the specifications in 2.2.

## 6. REMARK

### 6.1 Static voltage

Static voltage between signal load & ground may cause deterioration & destruction of the component. Please avoid static voltage.

### 6.2 Ultrasonic cleaning

Ultrasonic vibration may cause deterioration & destruction of the component. Please avoid ultrasonic cleaning

### 6.3 Soldering

Only leads of component may be soldered. Please avoid soldering another part of component.