

Part number: JYY-14P-4.0A1

1. Application (应用)

Piezoelectric Sounder External Drive type,featuring low power consumption, no EMI and high reliability, Usually it used in system do alarm or suggestive buzzer use.

它激式压电发声元件具有低功耗、无杂音、可靠性高的特点，通常它用在系统中做报警或提示的蜂鸣器用。

2. Maximum Rating(额定极限条件)

No.	项目 / Item	技术要求 / Specification
2.1	最大输入电压 / Maximum Input	30V _{P-P} Max.
2.2	工作温度 / Operating Temperature	-20°C ~ +70°C
2.3	储存温度 / Storage Temperature	-30°C ~ +80°C

3. Electrical Characteristics & Dimensions. (电性能和外形尺寸)

输出声压	Sound Pressure Level	85dB min. at 4.0kHz 5Vp-p Square Wave/10cm
谐振频率	Resonant Frequency	4.0±0.5kHz
静态电容	Static Capacitance	12.0nF±30% at 100Hz
消耗电流	Current Consumption	8mA max.(5Vp-p)
额定电压	Allowable input Voltage	30Vp-p max
工作温度	Operating Temperature Range	-20°C ~ +70°C
贮存温度	Storage Temperature Range	-30°C ~ +80°C
胶壳直径	Case Diameter	D=14.0±0.5mm
针脚高度	Pin height	H=4.0±0.5mm
针距	Terminal distance	d=7.5±0.5mm
胶壳材料	Case Material	PBT(Black)

Dimension:

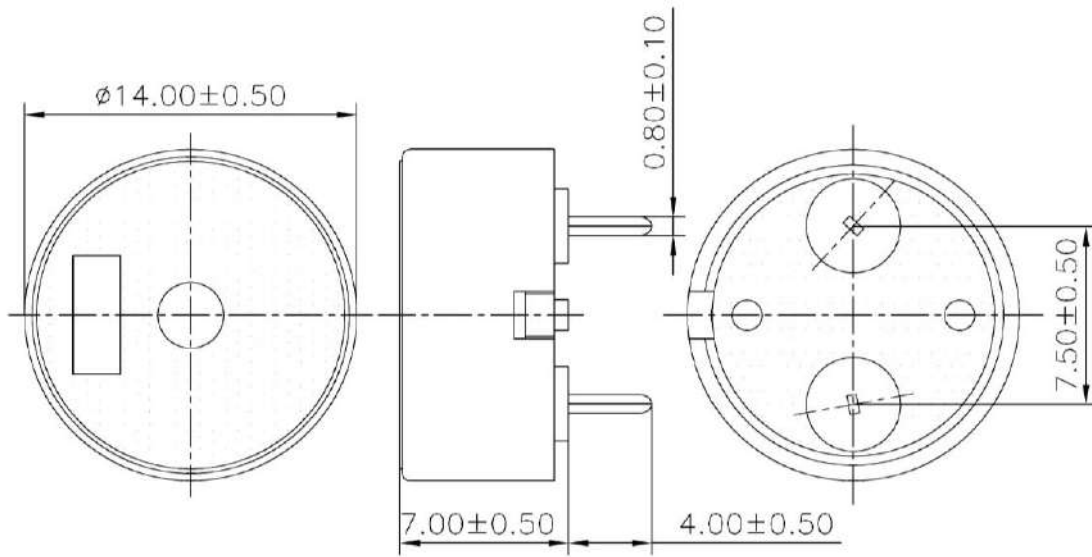

4. Measuring Method(测试方法)

4.1.S.P.L. Measuring Circuit (声压测试线路)

输入信号:5Vp-p,4.0KHz,方波

Input Signal:5Vp-p,4.0KHz,Square wave

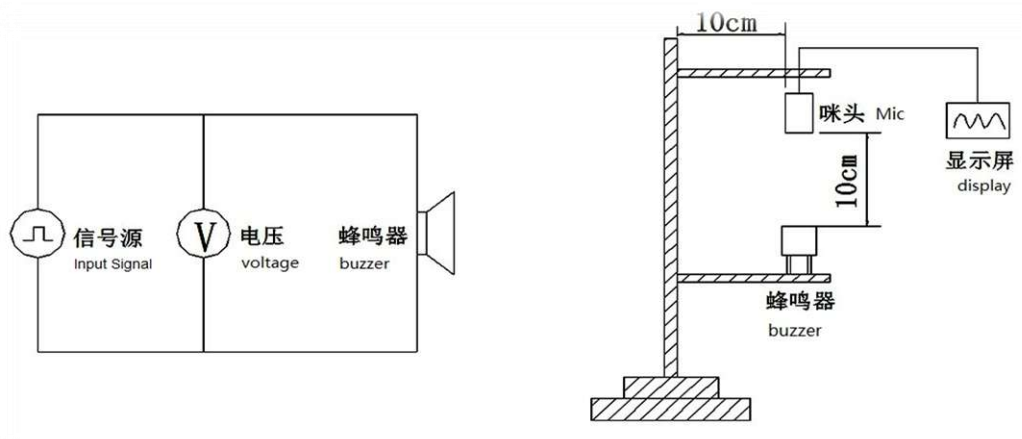

4.2. Measuring Condition (测试环境)

Normal measuring condition is used unless the standard condition is required.

除非要求采用标准的测试条件，否则将在常规测试条件下进行测量

常规测试条件 Normal measuring condition	标准测试条件 Standard measuring condition
--------------------------------------	--

Temperature = +15°C to +35°C, Humidity = 35% to 85% R.H.	Temperature = +25±3°C, Humidity = 35%±10% R.H.
---	---

5. Physical Characteristics(机械性能)

NO.	ITEM 内容	Test Condition 测试条件	Requirement 合格要求
5.1	Vibration Resistant 耐振动性	Sounder shall be measured after being applied vibration of amplitude of 1.5mm with 10 to 55Hz band of vibration frequency to each of 3 perpendicular directions for 2 hours. 振动频率10~55 Hz, 1.5mm 全振幅, XYZ 三个方向各2小时 试验后, 测试声响器.	85.0dB min. at 4.0kHz 5Vp-p Square wave/10cm
5.2	DROP 跌落试验	At the height of 1m for two times with the sound emission hole downwards 实验高度 1 米, 放音孔朝下, 跌落硬质木地板 2 次。 Note: The pins are allowed to deform after drop test. 注: 跌落实验, 允许插针弯曲.	
5.3	Soldering Heat Resistance 耐焊接性	Lead terminal are immersed up to 1.5mm from sounder's body in solder bath of +300±5°C for 3±0.5 seconds or +260±5°C for 10±1 seconds, and then sounder shall be measured after being placed in natural condition for 1 hours. 将声响器的插针插入(插至距声响器壳体 1.5mm 处为止) +300±5°C的焊锡槽 3±0.5 秒或+260±5°C的焊锡槽 10±1 秒, 然后在常温中放置 1 小时后, 测试声响器.	
5.4	Solderability 可焊性	Lead terminals are immersed in rosin for 5 seconds and then immersed in solder bath of +260±5°C for 3±0.5 seconds. 先将声响器的插针浸入松香液 5 秒钟, 然后浸入 +260±5°C 熔融的锡槽中 3±0.5 秒.	90% min. lead terminals shall be wet with solder. (Except the edge of terminal) 插针表面 90%以上 被焊锡润湿.(插

			针的段面除外)
5.5	Terminal Strength Pulling 插针强度	Buzzer every action since fracturing a, according to the opposite direction continuous bending two 45 degrees (a total of two) 蜂鸣器的每一根脚, 按相反方向连续弯曲两次 45 度(共两次)	Pin no fault, pin and ontology no looseness. 引脚无断裂, 引脚与本体无松动。

6. Environmental Characteristics(环境性能)

NO.	ITEM 内容	Test Condition 测试条件	Requirement 合格要求
6.1	Humidity 耐湿性	After being placed in a chamber with 90 to 95%R.H. at +85± 2°C for 48 hours and then being placed in natural condition for 1 hours, sounder shall be measured. 放置于 90% ~ 95% R.H., 温度+85±2°C 的环境试验箱内 48 小时, 然后取出, 在常温下放置 1 小时后, 测试声响器。	85.0dB min. at 4.0kHz 5Vp-p Square wave/10cm
6.2	Dry Heat Test (Storage) 高温放置	After being placed in a chamber with +85 ±2°C for 48 hours and then being placed in natural condition for 1 hours, sounder shall be measured. 放置于温度+85±2°C 的烘箱内 48 小时, 然后取出, 在常温下放置 1 小时后, 测试声响器。	
6.3	Cold Test (Storage) 低温放置	After being placed in a chamber with -30 ± 2°C for 48 hours and then being placed in natural condition for 1 hours, sounder shall be measured. 放置于温度-30±2°C 的制冷箱内 48 小时, 然后取出, 在常温下放置 1 小时后, 测试声响器。	
6.4	Temperature Cycle 高低温冲击	After being placed in a chamber at -30±2°C for 30 minutes, sounder shall be placed at room temperature. After 10 minutes at this temperature, sounder shall be placed in a chamber at +85±2°C. After 30 minutes at this temperature, sounder shall be returned to room temperature for 10	

	<p>minutes. After 10 above cycles, sounder shall be measured after being placed in natural condition for 1 hours.</p> <p>先放置于温度-30±2°C的制冷箱内30分钟，然后放置于室温10分钟后，放置于+85±2°C的烘箱内30分钟，再放置于室温10分钟。经过以上循环10次，在常温下放置1小后，测试声响器</p>	
--	--	--

7. Packaging Standard(标准包装信息)

Each minimum package unit of products shall be in a carton box and it shall be clearly marked with Part Number, quantity and outgoing inspection number.

There shall be no mechanical damage on products during transportation and/or in storage.

产品的外包装是纸箱,它应该清楚的标明型号,数量,出厂检验批号.

在运输及储存的过程中,产品必须不会受到机械损伤.

内包装一般用泡沫板、珍珠棉托盘或吸塑托盘包装，外包装为纸箱包装，应储存于阴凉、通风的库房。远离火种、热源。相对湿度不超过 80%。应与化学品分开存放，存放期限为两年。

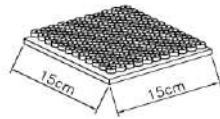

珍珠棉包装, 一板/100pcs
Pearl cotton packing, 100pcs

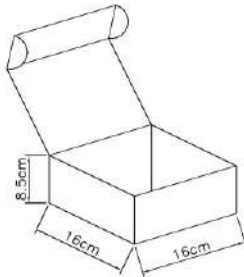

纸盒包装, 5板/500pcs
The carton packaging, 500pcs

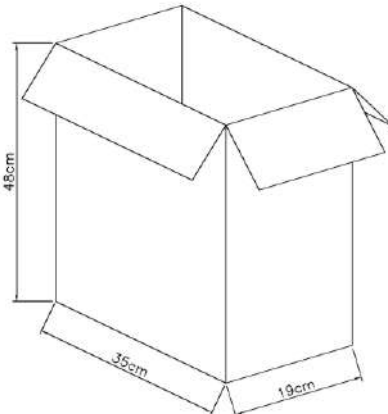

纸箱包装, 10盒/5000pcs
Carton packaging, 5000pcs

8. Cautions for Use

8.1 Please pay attention never to be applied DC voltage to piezo sounder.

请注意不要直接给压电蜂鸣器施加直流电压。

8.2 Washing of the component is not acceptable. Because it is not sealed.

该压电蜂鸣器不适合洗涤,因为它不密封。

8.3 In case of using solder iron for soldering, the top of soldering iron's temperature should be kept less than +350 °C. Moreover, the soldering time should be also kept with in 3seconds.

在使用烙铁的情况下,应注意烙铁头的温度应该保持在+350°C以下,并且焊接时间控制在3秒内。

8.4 The thickness of piezoelectric buzzer pin plating is generally in 5 μ m~8 μ m

压电蜂鸣器的引脚镀层厚度一般在5 μ m~8 μ m左右。

8.5 If the test result is unqualified after assembly, then can be removed and install another one, buzzer inside are generally design by the glue paste or card buckle, basically scrapped after dismantling.

如在装板后测试不良,可拆卸下来重新安装新的,蜂鸣器内部一般都是由胶水粘贴或者卡扣设计,拆解后基本报废。