

SPECIFICATION

受控

Customer:

Applied To:

Product Name: Piezo Transducer

Model Name: PCT-G4546E-K11081

Drawing No.: OEM11081R

Compliance with ROHS (本品符合 ROHS 指令)

--

Signature of KEPO

Issued by	Checked by	Approved by	Date
胡浩波	陈慧性		



宁波凯普电子有限公司

Ningbo Kepo Electronics Co., Ltd.

宁波东钱湖镇东钱湖工业区宝源路 25 号

TEL:+86-574-88370330

FAX:+86-574-88370329

ADD: No.25 Baoyuan road, Dongqian Lake Industry Area, Dongqian town, Ningbo City, China

Post Code: 315121

Email: Sales@chinaacoustic.com

<http://www.chinaacoustic.com>

SPECIFICATION PCT-G4546E-K11081	Page	2 / 7
	Revision No.	1.0
	Drawing No.	OEM11081R

CONTENTS

- 1.Scope范围
- 2.General概要
- 3.Maximum Rating.....额定极限条件
- 4.Electrical Characteristics.....电性能
- 5.Measuring Method.....测试方法
- 6.Physical Characteristics.....机械性能
- 7.Environmental Characteristics.....环境性能
- 8.Dimensions.....尺寸
- 9.Packaging Standard.....包装标准
- 10.Cautions.....警告
- 11.Cautions for Use.....注意事项

	2017.03.06		primary	
Rev.	DATE	PAGE	DESCRIPTION	SIGN
Revision		履历表		

SPECIFICATION PCT-G4546E-K11081	Page	3 / 7
	Revision No.	1.0
	Drawing No.	OEM11081R

1. Scope 范围

This product specification is applied to the piezoelectric sounder in alarm systems. Please contact us when using this product for any other applications than described in the above.

本规格书适用于压电式蜂鸣器，通常它用在系统中做报警或提示的蜂鸣器用，如果将该产品用于其它领域，请与我们联系。

2. General 概要

- 2.1 Out-Diameter 外径.....Ø45.5mm
- 2.2 Height 高度.....15.2mm
- 2.3 Weight 重量.....9g
- 2.4 Material/Color 材料/颜色.....PA66/Black

3. Maximum Rating 额定极限条件

	Item	Specification
3.1	Maximum Input Voltage 最大输入电压	30Vp-p Square Wave /max.
3.2	Operating Temperature Range 工作温度范围	-40 ~ +60℃
3.3	Storage Temperature Range 储藏温度范围	-40 ~ +60℃

4. Electrical Characteristics 电性能

	Item	Specification
4.1	Sound Pressure Level 声压	≥102dB/3.3KHz/12Vp-pSquare Wave/30cm
4.2	Capacitance at 100Hz容量	170-273nF

<h1>SPECIFICATION</h1> <h2>PCT-G4546E-K11081</h2>	Page	4 / 7
	Revision No.	1.0
	Drawing No.	OEM11081R

5. Measuring Method 测试方法

5.1 S.P.L. Measuring Circuit 声压测试线路

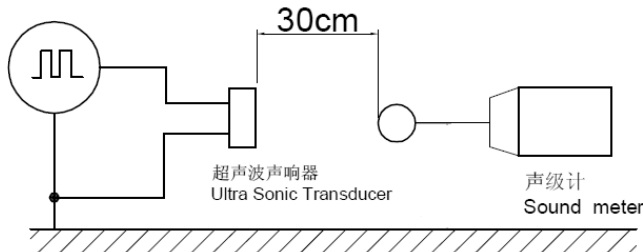

MIC : ND10 普通声级计或等同品
 MIC : ND10 S.P.L. or equivalent
 S.G. : DF1212 BL 音频扫频信号发生器或等同品
 S.G. : DF1212 BL Oscillater or equivalent

5.2 Measuring Condition 测试环境

Part shall be measured under a condition (Temperature :+5 to +35 °C ,Humidity :45 to 85%R.H.)unless the standard condition (Temperature :+25±3°C, Humidity :60±10%R.H.) is regulated measure.

温度+25±3°C，湿度 60±10%R.H.标准测试状态,在没有疑问的场合,可以在温度+5~+35°C,湿度 45~85%R.H.的范围内测试.

6. Physical Characteristics 机械性能

	Item	Test Condition	Specification
6.1	Shock 碰撞试验	Sounder shall be measured after being applied shock(490m/s ²) for each three mutually perpendicular directions to each of 3 times by half sine wave. 峰值加速度 490m/s ² , 半正弦波,XYZ 三个方向各 3 次冲击实验后,测试声响应器.	The measured value shall meet Table 1. 测试数据符合表 1.
6.2	Vibration Resistant 振动试验	Sounder shall be measured after being applied vibration of amplitude of 1.5mm with 10 to55Hz band of vibration frequency to each of 3 perpendicular directions for 2 hours. 振动频率 10~55 Hz,1.5mm 全振幅,XYZ 三个方向各 2 小时试验后,测试声响应器.	
6.3	Dropping 跌落	Dropped from 75cm high to linen with 2 times. 75cm 高度/2 回自然落到亚麻布垫上.	

SPECIFICATION PCT-G4546E-K11081	Page	5 / 7
	Revision No.	1.0
	Drawing No.	OEM11081R

7. Environmental Characteristics 环境性能

	Item	Test Condition	Specification
7.1	Dry Heat Test (Storage) 最高存储温度试验	After being placed in a chamber with $+60\pm 2^{\circ}\text{C}$ for 240 hours and then being placed in natural condition for 4 hours, diaphragm shall be measured. 在 $+60\pm 2^{\circ}\text{C}$ 的条件下放置 240 小时, 再在常温下放置 4 小时, 测试其数据.	The measured value shall meet Table 1. 测试数据符合表 1
7.2	Cold Test (Storage) 最低存储温度试验	After being placed in a chamber with $-40\pm 2^{\circ}\text{C}$ for 240 hours and then being placed in natural condition for 4 hours, diaphragm shall be measured. 在 $-40\pm 2^{\circ}\text{C}$ 的条件下放置 240 小时, 再在常温下放置 4 小时, 测试其数据.	
7.3	Humidity 湿度试验	After being placed in a chamber with 90 to 95%R.H. at $+40\pm 2^{\circ}\text{C}$ for 240 hours and then being placed in natural condition for 4 hours, diaphragm shall be measured. 在湿度为 90~95%R.H, 温度为 $+40\pm 2^{\circ}\text{C}$ 的条件下放置 240 小时, 再在常温下放置 4 小时, 测试其数据.	
7.4	Continuum run 连续运行	30Vp-p Square wave 3.3KHz/240hours 30Vp-p 方波 3.3KHz/240 小时	
7.5	Temperature Cycle 温度循环试验	After being placed in a chamber at $-40\pm 2^{\circ}\text{C}$ for 30 minutes, sounder shall be placed at room temperature($+20^{\circ}\text{C}$).After 15 minutes at this temperature ,sounder shall be placed in a chamber at $+60\pm 2^{\circ}\text{C}$. After 30 minutes at this temperature, sounder shall be returned to room temperature ($+20^{\circ}\text{C}$) for 15 minutes. After 5 above cycles, sounder shall be measured after being placed in natural condition for 4 hours. 先放置于温度 $-40\pm 2^{\circ}\text{C}$ 的制冷箱内 30 分钟, 然后放置于室温($+20^{\circ}\text{C}$)15 分钟后, 放置于 $+60\pm 2^{\circ}\text{C}$ 的烘箱内 30 分钟, 再放置于室温($+20^{\circ}\text{C}$)15 分钟. 经过以上循环 5 次,在常温下放置 4 小时后, 测试扬声器。	

Table 1. 表 1

	Item	Specification after test
1	Sound Pressure Level 声压	Initial Value $\pm 10\text{dB}$ 初始值 $\pm 10\text{dB}$

SPECIFICATION PCT-G4546E-K11081	Page	6 / 7
	Revision No.	1.0
	Drawing No.	OEM11081R

8. Dimensions 尺寸

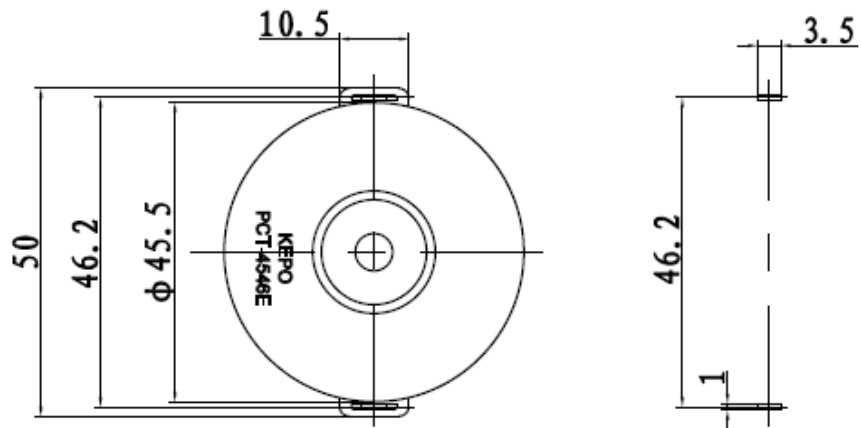

PCB FOOTPRINT

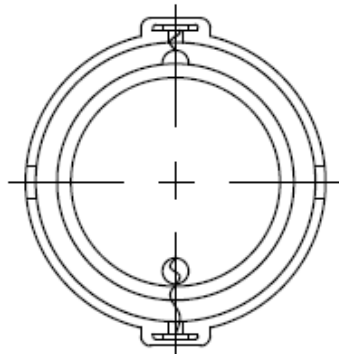
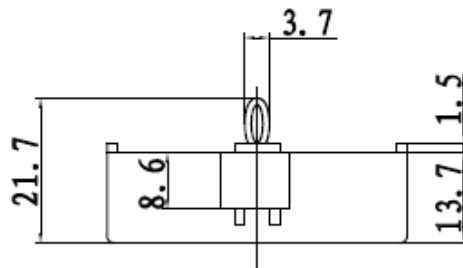

FIRST ANGLE PROJECTION :

Tolerance: ± 0.5

UNIT: mm

SPECIFICATION	Page	7 / 7
	Revision No.	1.0
PCT-G4546E-K11081	Drawing No.	OEM11081R

9. Packaging Standard 包装标准

Each minimum package unit of products shall be in a carton box and it shall be clearly marked with Part Number, quantity and outgoing inspection number.

There shall be no mechanical damage on products during transportation and/or in storage.

产品的外包装是纸箱,它应该清楚的标明型号,数量,出厂检验批号. 在运输及储存的过程中,产品必须不会受到机械损伤.

10. Cautions 警告

Please contact us before using our products for the undermentioned applications requiring especially high reliability in order to prevent defects which might directly cause damage to other party's life, body or property (listed below).

如果产品使用于下列高可靠性的装置时,请与我们联系,以免对人的生命,财产和身体造成损害.

- (1) Aircraft equipment 飞行设备
- (2) Aerospace equipment 航天设备
- (3) Undersea equipment 潜水设备
- (4) Medical equipment 医疗设备
- (5) Transportation equipment (auto mobiles, trains, ships) 交通设施
- (6) Traffic signal equipment 交通信号设备
- (7) Disaster prevention/crime prevention equipment 防灾害/防犯罪设备
- (8) Data-processing equipment 数据处理设备
- (9) Applications of similar complexity or reliability requirements comparable to the applications listed in the above 以及与上述相类似或可靠性要求更高的设备

11. Cautions for Use 注意事项

11.1 The component may be damaged if mechanical stress over this specification is applied.

如果产品所承受的机械应力超过规定的值,元件可能被破坏.

11.2 Please pay attention to protect operating circuit from surge voltage provided by something of force such as failing, shock and temperature changing.

请注意保护工作电路不会因失误,跌落和温度变化而产生浪涌电压.

11.3 Please pay attention never to be applied DC voltage to piezo sounder.

请注意永远不要给压电声听器施加直流电压.

11.4 Washing of the component is not acceptable. Because it is not sealed.

该声听器不适合洗涤,因为它不密封.

11.5 In case of using solder iron for soldering, the top of soldering iron's temperature should be kept less than +350°C. Moreover the soldering time should be also kept with in 3seconds.

在使用烙铁的情况下,应注意烙铁头的温度应该保持在+350°C以下,并且焊接时间控制在 3 秒内.